

Inside this issue

- 3 **Unlocking the secrets of cold-in-place asphalt recycling**
- 5 **Giving contractors some flexibility in project timing**
- 6 **Low-cost safety improvements for horizontal curves**
- 6 **Help with upgrading signs on high-speed curves**
- 7 **Library acquisitions**

Iowa State University's Center for Transportation Research and Education (CTRE) is the umbrella organization for the following centers and programs:

Bridge Engineering Center
Center for Weather Impacts on Mobility and Safety
Construction Management & Technology
Iowa Local Technical Assistance Program
Iowa Statewide Urban Design and Specifications
Iowa Traffic Safety Data Service
Midwest Transportation Consortium
National Concrete Pavement Technology Center
Partnership for Geotechnical Advancement
Roadway Infrastructure Management & Operations Systems
Sustainable Transportation Systems Program
Traffic Safety and Operations

ctre

Center for Transportation
Research and Education

IOWA STATE
UNIVERSITY

Focus on recent ISU research for improving local roads

Several ISU researchers have recently completed projects with implications for local roads. This issue of *Technology News* briefly summarizes three studies: improving the performance of granular shoulders, best practices for successful cold-in-place recycled

asphalt pavements, and using contracts with flexible start dates. Full reports for all projects, plus brief technical summaries, are online: www.ctre.iastate.edu/research.htm. Click "Completed research," or search for keywords using the Search CTRE function at the top of the page.

Improving granular shoulder performance

Stabilizing granular shoulders through a variety of materials and techniques can improve shoulder performance and safety to some degree, and reduce the need for repair activities.

These conclusions were recently reported by David White, associate professor of civil engineering at ISU. Along with a team of professors and students, White inspected various granular shoulders across the state, evaluated several stabilization techniques, and provided recommendations and tools for designing and constructing granular shoulders.

The project was sponsored by the Iowa Highway Research Board (TR-531).

Potential cost/performance issues

Roadway shoulders perform important functions. They provide space for extra-wide agricultural vehicles, emergency stops, and recovery of errant vehicles, as well as structural support and drainage for the pavement. Depending on traffic and other factors, those can be some pretty hefty performance requirements.

Compared to paved shoulders, granular shoulders can cost as much as 30 percent less to construct. But they also can experience performance problems like edge drop-off

(figure 1), rutting (figure 2), erosion, irregular slope, and settlement.

Granular materials are commonly used for roadway shoulders in Iowa, and local agencies can expend significant effort and money for frequent regrading, placement of additional virgin material or recycled hot-mixed asphalt or concrete, and recompaction, increasing short- and long-term maintenance costs.

granular shoulders continued on page 2



Figure 1. Edge drop-off was a feature of several granular shoulders examined in White's study

Acronyms in *Technology News*

AASHTO	American Association of State Highway and Transportation Officials
APWA	American Public Works Association
CTRE	Center for Transportation Research and Education (at ISU)
FHWA	Federal Highway Administration
Iowa DOT	Iowa Department of Transportation
ISU	Iowa State University
LTAP	Local Technical Assistance Program
MUTCD	Manual on Uniform Traffic Control Devices
NACE	National Association of County Engineers
TRB	Transportation Research Board



U.S. Department of Transportation
Federal Highway Administration



Iowa Department
of Transportation

LTAP is a national program of the FHWA. Iowa LTAP, which produces this newsletter, is financed by the FHWA and the Iowa DOT and administered by CTRE.

Center for Transportation Research and Education
ISU Research Park
2711 S. Loop Drive, Suite 4700
Ames, Iowa 50010-8664
Telephone: 515-294-8103
Fax: 515-294-0467
www.ctre.iastate.edu/

Any reference to a commercial organization or product in this newsletter is intended for informational purposes only and not as an endorsement. The opinions, findings, or recommendations expressed herein do not necessarily reflect the views of LTAP sponsors. All materials herein are provided for general information, and neither LTAP nor its sponsors represent that these materials are adequate for the purposes of the user without appropriate expert advice. ISU makes no representations or warranties, expressed or implied, as to the accuracy of any information herein and disclaims liability for any inaccuracies.

Iowa State University does not discriminate on the basis of race, color, age, religion, national origin, sexual orientation, gender identity, sex, marital status, disability, or status as a U.S. veteran. Inquiries can be directed to the Director of Equal Opportunity and Diversity, 3680 Beardshear Hall, 515-294-7612.

Subscribe to *Technology News*

Subscriptions to *Technology News* are free. We welcome readers' comments, questions, and suggestions. To subscribe, or to obtain permission to reprint articles, contact the editor (see page 4).

Subscribe to *Tech E-News*

For brief, e-mail reminders about upcoming workshops and other LTAP news, subscribe to Iowa LTAP's free service: Tech E-News. Send an email to Marcia Brink, mbrink@iastate.edu. Type "Subscribe Tech E-News" in the subject line.

granular shoulders continued from page 1

Shoulder conditions

Two problems showed up most often on granular shoulders inspected by White and his team:

- Edge drop-off (approximately 60 percent of inspected sites had an edge drop-off greater than 1.5 in.).
- Soft subgrades (about 50 percent of inspected sites had California bearing ratio [CBR] values less than 10 at depths between 8 and 10 in.).

Edge drop-off can be a safety issue (see "Pavement edge drop-off," *Technology News*, September–October 2006, www.ctre.iastate.edu/pubs/Tech_News/2006/sep-oct/edge_drop-off.pdf). Soft subgrades can contribute to shoulder rutting problems.

Recommendations

White's team tested various stabilization materials and techniques on both the granular material (primarily to reduce edge drop-off) and the soft subgrades (primarily to reduce rutting).

granular shoulders continued on page 4



Figure 2. Rutted, unstabilized shoulder (top)
Another shoulder area seven months after being stabilized with fly ash (bottom)

Unlocking the secrets of cold-in-place recycled asphalt pavements

Why do some cold-in-place recycled asphalt roadways perform better than others?

Chuck Jahren and Hosin “David” Lee, associate professors of civil engineering at ISU and The University of Iowa, respectively, recently teamed up to identify key performance factors. The quality of subgrade support proved to be more important than traffic levels for predicting CIR asphalt pavement performance.

The project was sponsored by the Iowa Highway Research Board (TR-502).

What is CIR?

In Iowa, cold-in-place recycling (CIR) has been a popular rehabilitation method for asphalt roads since about 1986. Generally, asphalt (three to four inches) is milled off the surface of the existing pavement, then crushed and screened to size, mixed with a stabilizing and/or rejuvenating agent, and relaid and compacted near its original location.

The process may be accomplished with a recycling train (figure 1). A top surface consisting of hot-mix asphalt (HMA) or a seal coat may also be applied (figure 2).

The advantages of this rehabilitation process are self-evident: Agencies can build on a consistent structural layer that’s already in place, while reducing construction costs

related to fuel usage, traffic disruption, and use of resources like aggregate and asphalt binder.

Performance

But in Iowa, some CIR pavements recycled under similar weather and construction conditions and experiencing similar traffic levels have had inconsistent performance records.

Jahren and Lee and their team examined 24 CIR roads rehabilitated between 1986 and 2004. The roads were classified according to CIR pavement age, subgrade support condition, and average annual daily traffic. All but two of the roads studied had traffic levels less than 2,000 AADT.

For each road segment studied, the team assessed pavement performance in the field and assessed materials properties related to performance in the laboratory. They calculated a pavement condition index (PCI) value for each pavement; inferred structural support and layer stiffness using falling weight deflectometer (FWD) testing and computer analysis; and tested indirect tensile strength and asphalt binder properties of core samples.

Key findings

Good subgrade support is a primary predictor of CIP recycled pavement performance.

- The average predicted service life for the roads studied in this project is up to 34 years for roads with good subgrade support; 22 years when subgrade support is poor.
- CIR pavements with poor subgrade support experience more rutting, patching, and edge cracking.
- Traffic level does not seem to affect CIR pavement performance as much as subgrade support. All pavements in the study with good subgrade support performed equally well under different traffic conditions.

CIR continued on page 4

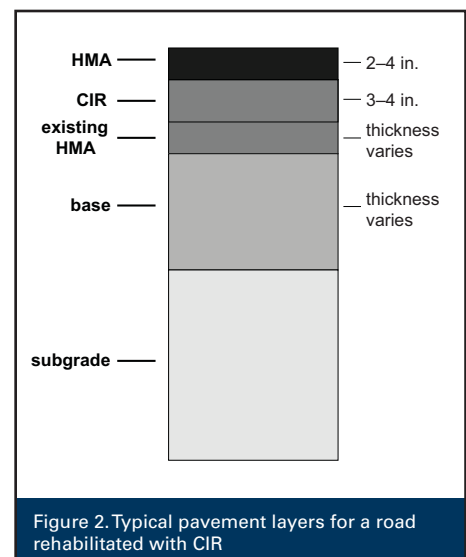

Figure 2. Typical pavement layers for a road rehabilitated with CIR

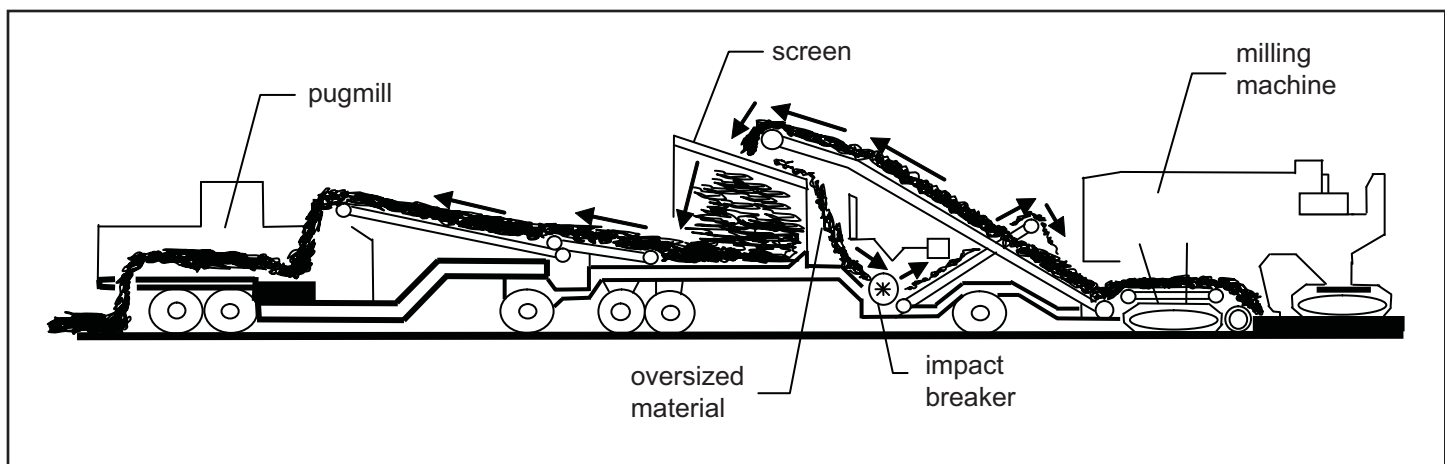

Figure 1. Diagram of a typical CIR milling, screening, crushing, and pugmill unit, traveling left to right; paving and compaction units not shown (from Jahren et al., 1998, *Review of Cold In-Place Recycled Asphalt Concrete Projects*, IHRB Project HR-392)

Iowa LTAP Mission

To foster a safe, efficient, and environmentally sound transportation system by improving skills and knowledge of local transportation providers through training, technical assistance, and technology transfer, thus improving the quality of life for Iowans.

Staff

Shashi Nambisan
Director of CTRE
shashi@iastate.edu

Duane Smith
Director of Iowa LTAP
desmith@iastate.edu

Marcia Brink
Communications Manager and Editor
mbrink@iastate.edu

Tom McDonald
Safety Circuit Rider
tmcdonal@iastate.edu

Georgia Parham
Secretary
gparham@iastate.edu

Alison Weidemann
Designer

Christianna White
Contributing Writer

Advisory Board

The professionals listed below help guide the policies and activities of Iowa LTAP. Contact any of the advisory board members to comment, make suggestions, or ask questions about any aspect of LTAP.

Royce Fichtner
Marshall County Engineer
641-754-6343
rfictner@co.marshall.ia.us

Gary Fox
Transportation Director, City of Des Moines
515-283-4973
glfox@dmgov.org

John Goode
Monroe County Engineer
641-932-7123
jgoode@monroecoia.us

Neil Guess
Howard R. Green Company
515-278-2913
nguess@hrgreen.com

Bret Hodne
City of West Des Moines
515-222-3480
bret.hodne@wdm-ia.com

Larry Jesse
Iowa DOT, Office of Local Systems
515-239-1291
larry.jesse@dot.iowa.gov

Joe Jurasic
Operations Engineer, FHWA-Iowa Division
515-233-7321
joe.jurasic@fhwa.dot.gov

Wally Mook
Director of Public Works, City of Bettendorf
319-344-4128
wmook@bettendorf.org

Charlie Purcell
Iowa DOT, Office of Local Systems
515-239-1532
charlie.purcell@dot.iowa.gov

Christy VanBuskirk
Keokuk County Engineer
641-622-2610
cvanbuskirk@keokukcountyia.gov

Dan Waid
Hamilton County Engineer
515-832-9520
dwaid@hamiltoncounty.org



Printed with soy ink

granulated shoulders continued from page 2

The field tests, along with data from corresponding lab tests, were used to develop charts for designing granular shoulders for minimum rutting and predicting the rutting behavior of existing ones. Variables include CBR values of subgrade and of granular layer, axle loads, and rut depth.

In both the lab and the field, stabilizing soft subgrades with fly ash or geogrid was effective at reducing rutting (figure 2).

In lab tests, stabilizing the granular shoulder materials with portland cement, polymer emulsions, or soybean oil showed promise for inhibiting edge rutting or drop-off.

Field results with these materials, however, were disappointing. Edge ruts redeveloped over a short time. The team hopes to conduct additional research, focusing on improved mixing and compaction methods and equipment.

To reduce rutting, the team recommends designing granular shoulders with appropriate CBR values for both the

subgrade and granular layers, accounting for expected traffic level and loads.

The weighted average CBR value of the granular layer should be at least 10. The weighted average CBR value of shoulder fill and subgrade up to a depth of 20 in. should be at least 12. Dynamic cone penetrometer and Clegg impact tests can be used to assess in situ CBR values during shoulder construction.

The increased initial construction costs of these stabilizing techniques will not be totally offset by reduced maintenance activities. Stabilized granular shoulders have the potential, however, to enhance performance and safety, which can be difficult to quantify.

For more information

Contact David White, 515-294-1463, djwhite@iastate.edu. The full project report, including design charts, and a technical summary are online, www.ctre.iastate.edu/pga/detail.cfm?projectID=-28778605. ■

CIR continued from previous page

The CIR pavement layer appears to act as a stress-relieving layer. Within the range of data analyzed, a less stiff and more porous CIR layer performs well. An appropriate range of values for stiffness and air voids has not been determined but will likely be different from those for hot-mix asphalt.

Recommendations

Decision makers are encouraged to use available tools for determining if a specific pavement is a good candidate for CIR.

In particular, consider using falling-weight deflectometer or dynamic cone penetrometer (figure 3) testing to evaluate the subgrade's ability to provide proper support.

Life-cycle cost analyses should reflect CIR performance curves developed in this study.

For more information

Contact Chuck Jahren, 515-294-3829, cjahren@iastate.edu. The full project report,

including design charts, and a technical summary are online, www.ctre.iastate.edu/research/detail.cfm?projectID=1063747601. ■



Figure 3. Operating dynamic cone penetrometer

Giving contractors some flexibility in project timing

Contractors benefit from flexible-start/fixed-duration contracts, which provide less-rigid project start dates. What about the owner-agencies? What risks, benefits, and/or drawbacks, if any, do they experience with these contracts?

To answer that question, civil engineering professors Kelly Strong, Amr Kandil, and Tom Maze at ISU recently reviewed common practices and experiences with flexible-start/fixed-duration contracts, from the owner-agencies' point of view. They surveyed the DOTs in Washington, Minnesota, and Missouri, all states with a fair amount of experience with flexible-start/fixed-duration contracting. Although only state agencies were surveyed, findings may be useful for city and county agencies.

Innovative contracting

To reduce construction costs and traffic disruptions for transportation projects without sacrificing quality, several agencies are trying innovative bidding and contracting methods.

One such method is flexible-start/fixed-duration contracting. In general, such contracts allow the contractor flexibility in when to start the project, as long as the project is completed within a contracted period of time.

The researchers found that agencies have used various features in flexible-start/fixed-duration contracts to retain a necessary level of control over project timing. For example,

- Combine a flexible start-date window with a latest-allowable project completion date.
- Require a minimum lead-time for the contractor to notify the agency before starting work.
- Include an incentive/disincentive clause (see sidebar).

Potential benefits

In general, flexible-start/fixed-duration contracts ultimately benefit the owner-agency and the public by potentially reducing construction costs and, often, the duration of traffic closures.

When contractors have some latitude in starting specific projects, they can allocate resources like labor and material supplies more efficiently among various projects. As a result, they can submit lower bids.

Briefer traffic closures not only expose construction workers to work zone hazards for shorter periods of time, but make travelers happier.

Good candidates

Flexible-start/fixed-duration contracting could be considered for almost any job, but

it is probably best suited for projects that require

- Closing roads or sections of roads, causing major traffic disruption.
- Substantial off-site pre-construction preparation work.

Poor candidates

Flexible-start/fixed-duration contracting is probably less suited for projects if

- Delaying the start date would cause major inconvenience to local businesses or the public. For example, banks, emergency service providers, and hospitals may need more lead time than required by the contract if traffic will have to be rerouted in their locale during construction.
- A major trip-generating event, like a state fair or major athletic event, will occur during the potential construction period.
- Emergency or fast-track work is involved.

Other considerations

Giving the contractor some flexibility means that staff at the local agency will have to be flexible, too. This can be a challenge, especially for onsite project inspectors.

In general, flexible-start/fixed-duration contracting hasn't compromised project safety. Still, the agency should pay close attention to critical-path activities, especially if the contract offers an early-completion bonus.

Some contracts include early-completion incentives for only the portion of a project that involves closing the roadway. Such contracts should clearly state the effect on any earned incentive if the overall project is not completed within the contracted time.

For more information

Contact Strong, 515-294-1460, kstrong@iastate.edu, or Maze, 515-294-9523, tmaze@iastate.edu. The full report is available online, <http://www.ctre.iastate.edu/smartwz/reports/2007-maze-flex-schedule.pdf>.

This project was sponsored by the Midwest Transportation Consortium and Smart Work Zone Deployment Initiative. ■

Other innovative bidding methods

A+B bidding can lower project costs by reducing project duration. The A parameter represents the estimated cost of the project; the B parameter represents the length of time the contractor estimates for conducting the project. In general, the lowest A + B bid is awarded the contract.

Incentive/disincentive contracts

motivate contractors to complete projects quickly by offering a bonus for completing work ahead of schedule. If work is completed late, pay is reduced by a monetary penalty—often a value per unit of time the project extends beyond contracted end date.

Resources for more information

- Utah LTAP summary of best practices in innovative contracting: www.ic.usu.edu/
- FHWA's Contracting website: www.fhwa.dot.gov/programadmin/contracts/price.cfm
- FHWA's innovative contracting Fact Sheets: www.fhwa.dot.gov/construction/fs01026.cfm
- Joe Jurasic at Iowa's FHWA division office, 515-233-7300, joe.jurasic@fhwa.dog.gov; Gerald Yakowenko in Washington, D.C., 202-366-1562, gerald.yakowenko@fhwa.dot.gov

Low-cost safety improvements for horizontal curves

Nearly 25 percent of fatal crashes occur at or near a horizontal curve.

Addressing safety problems at horizontal curves is one of 22 emphasis areas in AASHTO's Strategic Highway Safety Plan and is also a goal of FHWA's safety focus area related to road departures.

As a result of these emphases, the FHWA has recently developed a publication providing practical information on several low-cost treatments to address identified or potential safety problems at horizontal curves.

The 60-page booklet, *Low-Cost Treatments for Horizontal Curve Safety*, concisely describes each treatment, shows examples, suggests when the treatment might be applicable, provides design features, and includes information about potential safety effectiveness and costs, if available. It concludes by describing maintenance activities to maximize the duration of treatment effectiveness.

Suggested treatments include the following:

- Basic traffic signs and markings found in the MUTCD
- Enhanced traffic control devices
- Additional traffic control devices not found in the MUTCD
- Rumble strips
- Minor roadway improvements
- Innovative and experimental treatments

Free copies of the publication are available from the FHWA Report Center, 9701 Philadelphia Ct., Unit Q, Lanham,

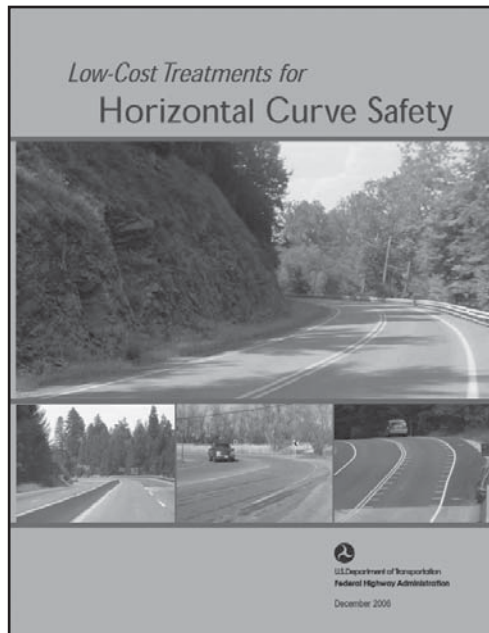

MD 20706. Call 301-577-0906, and ask for report no. FHWA-SA-07-002.

The booklet is also online for download as a pdf: http://safety.fhwa.dot.gov/roadway_dept/pubs/sa07002/index.htm. ■

Help with upgrading signs on high-speed curves

In Iowa, 39 percent of fatal crashes result from single vehicles running off roads, which often happens when drivers under-estimate curves.

A CTRE study found that 11 percent of fatalities on primary highway curves in Iowa occurred at just 30 curves.

Because of that finding, safety funds were awarded to supply oversized, fluorescent yellow chevron signs to those locations, with good results.

If you have a high-speed curve that has a documented history of multiple severe crashes, you may want to consider

upgrading the chevron signing.

For more information

Contact Tom Welch, safety engineer, Office of Traffic and Safety, Iowa DOT, 515-239-1267, tom.welch@dot.iowa.gov. ■

Stanley L. Ring Memorial Library:

New acquisitions

Note about delivery of materials: *The library now send orders through the U.S. Postal Service. This change is resulting in important savings for LTAP, but ordered materials do not arrive as quickly. If you have an urgent need for library materials, let us know when you place your order and we will arrange faster delivery.*

Three ways to order LTAP library materials

- Use the online catalog, www.ctre.iastate.edu/library/search.cfm.
- Contact Jim Hogan, library coordinator, 515-294-9481, hoganj@iastate.edu, fax 515-294-0467.
- Mail or fax the order form on the back cover of *Technology News*.

CD-ROM

CR 89 Access Management Library

This CD contains the proceedings of the Sixth National Conference on Access Management (2005), plus more than 100 reference documents on access management. It complements DVD 151.

CR 90 Reduce Congestion through Access Management

This CD contains the results of a scanning tour of Dakota County, Minnesota, and the Gateway 1 Corridor in Brewer, Maine. It also contains a video overview of access management illustrating how reducing conflict points increases traffic capacity and safety.

DVD

DVD 151 Access Management Library

This DVD contains videos on access management from FHWA, Missouri, New Hampshire, Florida, Kansas, and Iowa. It complements CR 89.

Publications

P 1707 Journal of the Transportation Research Board No. 1989: Low-Volume Roads

Two volumes contain 80 technical papers related to low-volume road systems that were presented at TRB's 2007 International Low-Volume Roads Conference. Topics include planning, environment, design, maintenance, structures, materials, pavements, and construction.

P 1702 Access Management, Location, and Design

This is a participant workbook designed to be used with a three-day National Highway Institute course but can be used as a stand-alone document. The course provides technical background for evaluating existing access location and design standards and guidelines, together with the rationale for "best practices."

P Access Management Manual

This TRB-sponsored manual provides a summary of the state of the art on access management. It is intended to assist state transportation agencies, metropolitan planning organizations, and local governments in developing and implementing access management programs.

P 1704 Roadside Weed Management

This FHWA-sponsored handbook is a guide to best practices for managing invasive vegetative species along roadsides. It contains essays on prevention and control of pest plant invasions, summaries of relevant regulations and policies at federal and state levels, and a state-by-state compilation of noxious species lists and agency contacts.

LTAP Materials

- ✓ Order library materials
- ✓ Send *Technology News* to a friend
- ✓ Correct your mailing information

To make a change to the *Technology News* mail list or to order library materials, please complete the information below and mail or fax this page (including mail label) to CTRE's address below:

Center for Transportation Research and Education

2711 S. Loop Drive, Suite 4700

Ames, IA 50010-8664

Fax: 515.294.0467

- Add the following name/address to the *Technology News* mail list.
- Correct the name and/or address below on the *Technology News* mail list.

New or corrected mailing information:

Name _____

Title _____

Organization _____

Address _____

City _____

State _____ Zip _____

- Delete the name/address below from the *Technology News* mail list.
- Send the following library materials to the address below (or to the corrected address above):

Title: _____

P-, V-, DVD or CR-number: _____

Title: _____

P-, V-, DVD or CR-number: _____

Subscribe to *Technology News* online at

www.ctre.iastate.edu/pubs/Newsletter_Request/mailform.cfm.

P 486-0524

Technology News

Center for Transportation Research and Education

ISU Research Park

2711 S. Loop Drive, Suite 4700

Ames, IA 50010-8664

RETURN SERVICE REQUESTED