

THIS IS AN ARCHIVED FIGURE AND IS NO LONGER MAINTAINED AS PART OF THE SUDAS STANDARD SPECIFICATIONS. THIS FIGURE MAY CONFLICT WITH THE CURRENT SPECIFICATIONS, AND SECTION AND FIGURE REFERENCES MAY NO LONGER BE VALID.

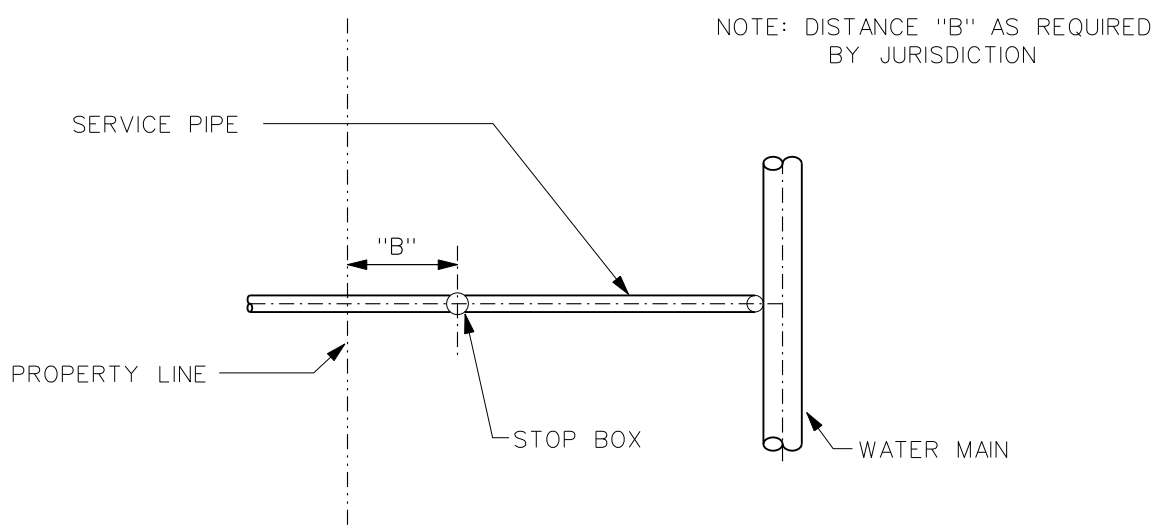

PLAN

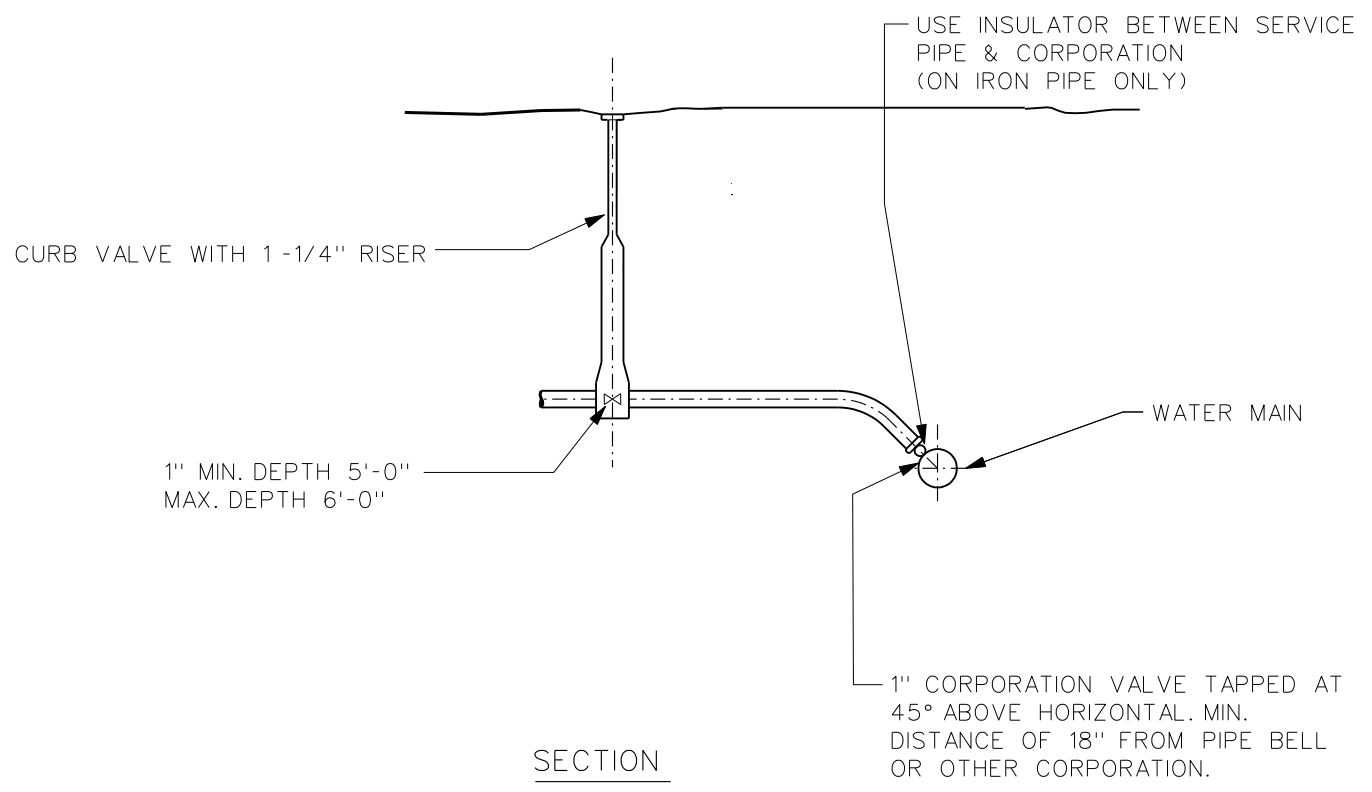

SECTION