

TYPE A WITH FLARES

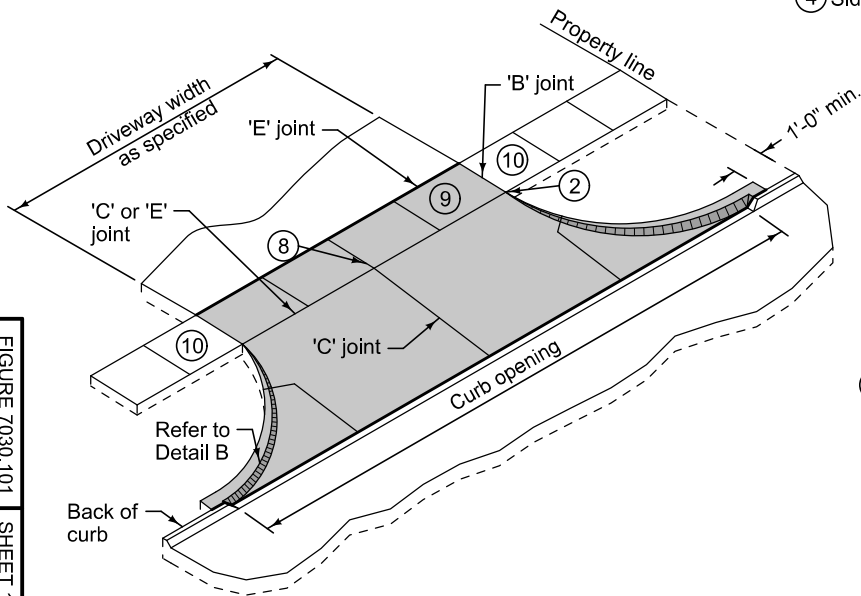

TYPE A WITH RADII

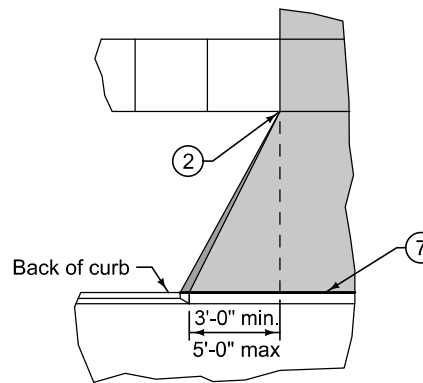

DETAIL A
(Residential/Agricultural Only)

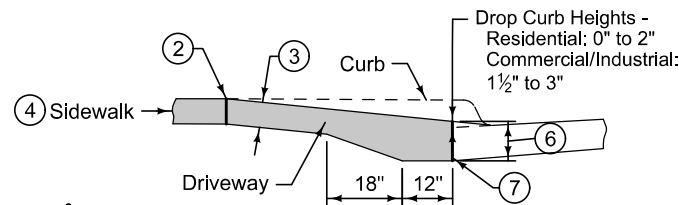

TYPICAL SECTION

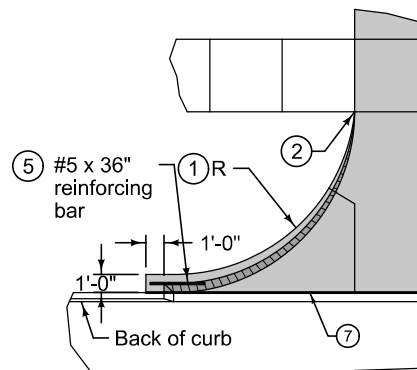

DETAIL B

- ① Driveway radius (R).
Residential: 10 foot minimum, 15 foot maximum.
Commercial and industrial: As specified in the contract documents.
- ② Transition the curb height to 0 inches at end of taper/radius or at the front edge of sidewalk. Do not extend raised curb across sidewalk.
- ③ Pavement thickness.
Residential: 6 inches minimum.
Commercial and industrial: 7 inches minimum.
- ④ Sidewalk thickness through driveway to match thickness of driveway.
- ⑤ Center reinforcing bar vertically in the pavement.
- ⑥ Match thickness of adjacent roadway, 8 inches minimum.
- ⑦ Provide 'E' joint at back of curb unless 'B' joint is specified.
- ⑧ For alleys, invert the pavement crown 2% toward center of alley.
- ⑨ Target cross slope of 1.5% with a maximum cross slope of 2.0%. If specified in the contract documents, construct the sidewalk through the driveway 5 feet wide to serve as a passing space.
- ⑩ If cross slope of adjacent sidewalk panel exceeds 2.0%, remove and replace to transition from existing sidewalk to sidewalk through driveway. If elevation change requires a curb ramp, comply with Figure 7030.205; verify need for detectable warning panel with Engineer.

	REVISION 3 2020 Edition
	7030.101 SHEET 1 of 1
SUDAS Standard Specifications	
CONCRETE DRIVEWAY, TYPE A	