

TYPE B WITH FLARES

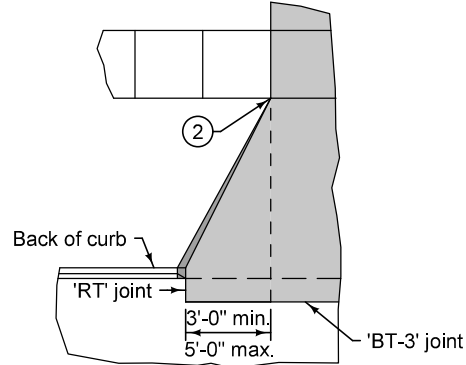

DETAIL A
(Residential/Agricultural Only)

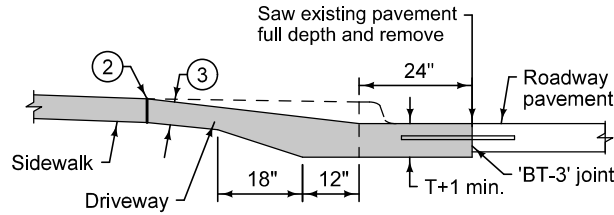

SECTION A-A

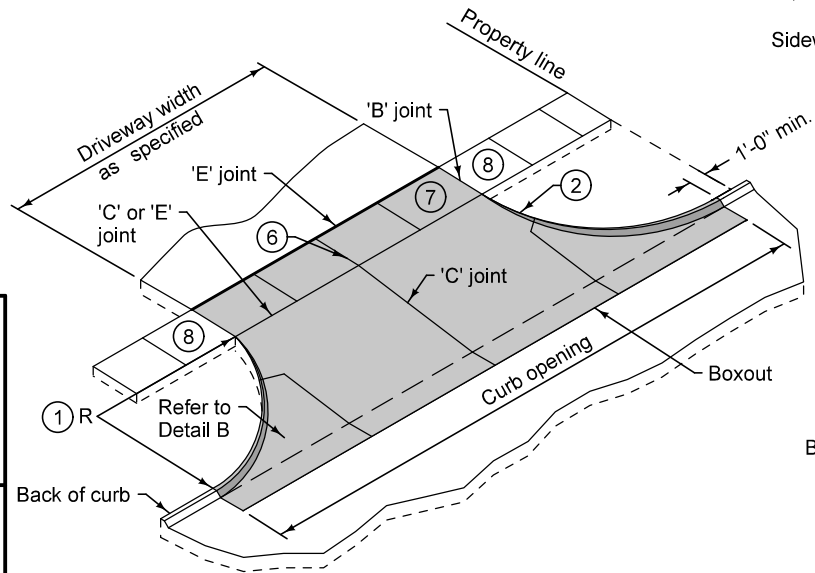

TYPE B WITH RADII

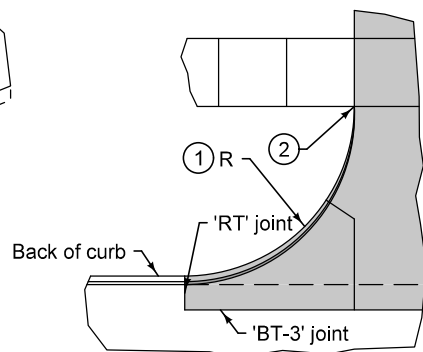

DETAIL B

- ① Driveway radius (R).
Residential: 10 foot minimum, 15 foot maximum.
Commercial and industrial: As specified in the contract documents.
- ② Transition the curb height to 0 inches at end of taper/radius or at the front edge of sidewalk. Do not extend raised curb cross sidewalk.
- ③ Pavement thickness.
Residential: 6 inches minimum.
Commercial and industrial: 7 inches minimum.
- ④ Sidewalk thickness through driveway to match thickness of driveway.
- ⑤ If longitudinal joint is located 48 inches or less from the back of curb, extend boxout to joint line. Full depth saw cut is still required.
- ⑥ For alleys, invert the pavement crown 2% toward the center of the alley.
- ⑦ Target cross slope of 1.5% with a maximum cross slope of 2.0%. If specified in the contract documents, construct the sidewalk through the driveway 5 feet wide to serve as a passing space.
- ⑧ If cross slope of adjacent sidewalk panel exceeds 2.0%, remove and replace to transition from existing sidewalk to sidewalk through driveway. If the elevation change requires a curb ramp, comply with Figure 7030.205; verify need for detectable warning panel with Engineer.

FIGURE 7030.102 SHEET 1 OF 1

	<small>REVISION</small> 3 2020 Edition
	SUDAS 7030.102 <small>SHEET 1 of 1</small>
SUDAS Standard Specifications	
CONCRETE DRIVEWAY, TYPE B	