

Temporary Traffic Control Devices

Traffic control devices are any signs, signals, markings, or other items used to guide, warn, and regulate traffic. Traffic control devices are the major means of communication for road users; thus it is most important that design, condition, and placement be proper at all times. All devices used in work zones shall comply with the provisions of the MUTCD. In addition, sign design must comply with the *Standard Highway Signs* manual. Do not install temporary traffic control devices until work is ready to begin. The MUTCD requires all temporary traffic control devices to be promptly removed or covered when no longer needed. Signs are the most common type of work zone traffic control device, categorized into three types:

- regulatory
- warning
- guide

The MUTCD requires all signs to be retroreflective or illuminated when used at night. Roadway lights are not sufficient as illumination sources. Supplemental nighttime warning lights may be required in pedestrian or recreational areas.

A. Regulatory Signs

Regulatory signs inform users about traffic laws and regulations. Because these signs impose legal obligations, they must be used properly and only with prior official authorization by the local agency. Regulatory signs are generally rectangular with a black legend and border on a white background. Exceptions include the STOP, YIELD, DO NOT ENTER, WRONG WAY, and ONE WAY signs. STOP (R1-1), ROAD CLOSED (R11-2), and SPEED LIMIT (R2-1) are all regulatory signs. Specific requirements for road closures are discussed in detail later in this chapter.



R1-1



R11-2

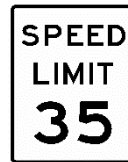

R2-1

B. Warning Signs

Warning signs draw attention to conditions on or near the roadway that may not be readily apparent. These signs are generally diamond-shaped with an orange background and black lettering or symbols; although other colors are allowed for a few specific signs. Examples of common warning signs are the FLAGGER (W20-7a) and the ROAD WORK AHEAD (W20-1) sign. Advisory speeds on warning plaques are not enforceable; use for guidance only.



W20-1



W20-7



W21-6



W21-7

C. Guide Signs

Guide signs advise drivers and pedestrians about navigating through the work zone. These signs are normally orange with black lettering. An example of a guide sign is END ROAD WORK (G20-2).



G20-2

D. Sign Dimensions

Sign size and legend are critical for road user recognition and understanding. Based on traffic speed, use the following guidelines when deciding sign dimensions. For best performance, use larger signs, even in low-speed areas.

- **High speed roadway (35 mph and above):** Advance warning signs shall be at least 48 inches by 48 inches. In general, uppercase lettering should be at least 7 inches high.
- **Moderately low traffic volumes and speeds (25 to 35 mph):** The MUTCD allows 36 inches by 36 inches, with an uppercase lettering size of 5 inches.
- **Low speed local roads and streets (25 mph or below):** Smaller advance warning signs, 30 inches by 30 inches, may be allowed, with sign messages short and symbols clear in meaning.

E. Sign Installation

Consider the position of signs relative to the roadway and the spacing between the signs when installing temporary traffic control. The MUTCD requires that long-term stationary work zones (more than three consecutive days in one location) use post-mounted advance warning signs. Minimum dimensions for post-mounted signs are shown on the figure below.

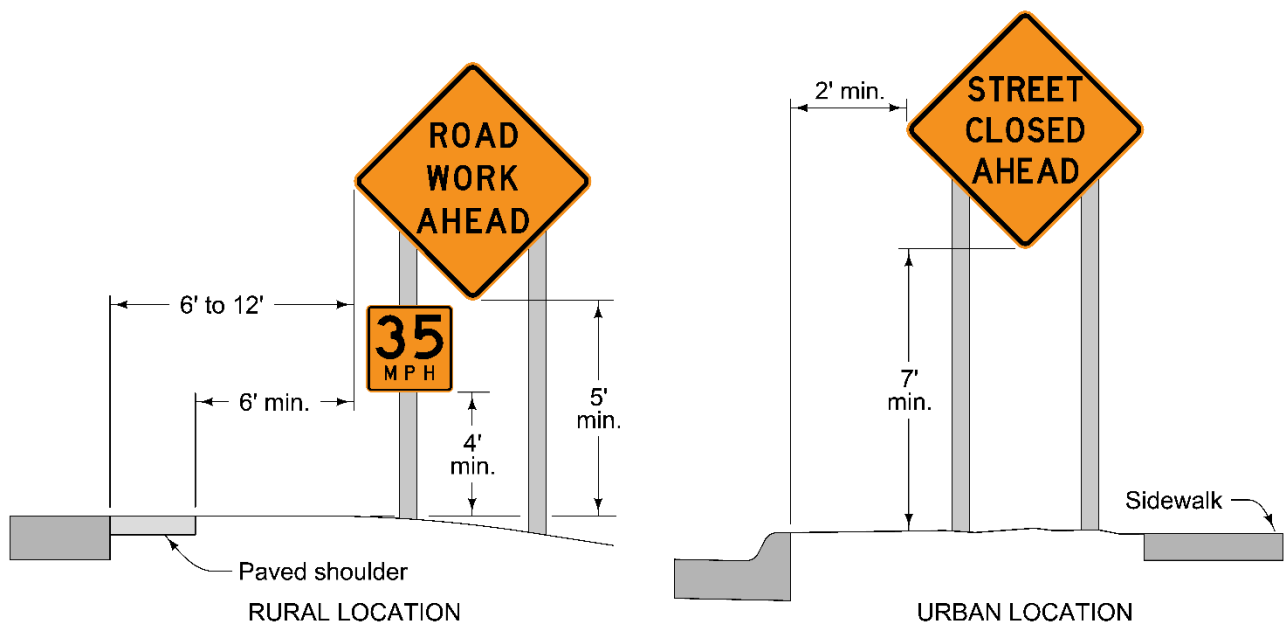

Supplemental plaques may be mounted 1 foot lower than the primary sign. If installed within the clear zone, sign supports shall be crashworthy or shielded. Signs should not be positioned on sidewalks or bicycle facilities in urban areas, and any signs with less than a 7 foot mounting height should not project more than 4 inches into pedestrian facilities.

Portable sign mounting is used for work zone applications lasting less than 3 days. The supports shall be crashworthy.

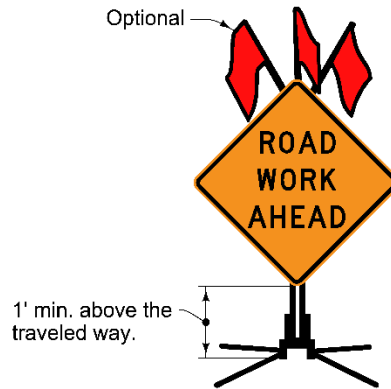

Several designs have been approved, but any used in the clear zone shall be crashworthy per the test and evaluation criteria of National Cooperative Highway Research Program (NCHRP) Report 350 or Manual on Assessing Safety Hardware (MASH). Fabric, roll-up, portable signs are popular because they are lightweight and easy to install. However, some designs are too flexible in windy conditions, degrading visibility. Flexible base portable signs that do not provide necessary stability in windy situations shall be adequately supported, or work activities must be terminated. Both the requirements for crashworthiness and adequate visibility shall be met with all work zone signs. Other installation methods for work zone signs include vehicle and barricade mounting. Do not allow post-mounted signs to encroach on sidewalks, shared use paths, or bike lanes or place portable signs on them unless those facilities are officially closed.

Vehicle-mounted signs should be high enough for adequate visibility for approaching vehicles, suggested at least 4 feet above the ground surface.



Barricade mounted signs shall be at least 1 foot above the traveled way. In addition, signs on Type III barricades should not cover more than 50% of the top two rails and not more than 33% of all three rails.

F. Spacing of Signs

Appropriate spacing is crucial for road users' reaction to work zone signs. Spacing depends on several factors, including speed of traffic, type of roadway, locations of intersections or major driveways, vertical and horizontal roadway alignment, and physical obstructions in the work area. If road users don't seem to be recognizing the signs, consider increasing the sign spacing and/or size and adding flags or warning lights.

The MUTCD contains guidance for minimum spacing of signs in Section 6C.04. A basic "rule of thumb" for warning sign placement is 4 to 8 times the speed limit in urban areas and 8 to 12 times the speed limit in rural locations. Table 3 illustrates these minimum guidelines. The positions of the signs should be adjusted for available sight distance.

Table 13B-2.01: Distance Between Signs

Speed Limit (mph)	Spacing (ft)
25	100
35	250
45	350
55	500

G. Channelizing Devices

Channelizing devices warn about work zone conditions and guide road users through or around the work area. Several types of channelizing devices are available, including cones, vertical panels, channelizers, tubular markers, drums, and barricades - with new types continually being developed and approved. Promptly repair, clean, or replace any devices that are damaged, dirty, or deficient in retroreflectivity.

- Ballast:** Ballast is often required to maintain position and stability of channelizing devices, and proper placement and type of ballast is important. Follow these guidelines:
 - Never place ballast on top of channelizing devices; keep ballast on the lower part of the device.
 - Use sandbags or weighted bases, and do not use items such as rocks, broken concrete, etc., for ballasting.
- Spacing of Devices:** Like signs, spacing of channelizing devices in work zone applications depends primarily on traffic speed. A rule of thumb suggested by the MUTCD for maximum spacing is the speed limit when used in merging or shifting taper applications and twice the speed limit for tangent applications. Closer spacing should be considered where drivers might need more guidance, such as in horizontal curves or in low-speed applications.

Table 13B-2.02: Channelizing Device Spacing

Speed Limit (mph)	Taper (ft)	Buffer (ft)	Work Space (ft)
25	25	50	50
30	30	60	60
35	35	70	70
40	40	80	80
45	45	90	90
50	50	100	100
55	55	110	110

3. Types of Devices:

- a. **Cones:** Cones are required to be predominantly orange in color. Retroreflective striping is required for night use. To maintain proper position, ballasting as described earlier may be employed, or cones can be nested to increase weight and stability.

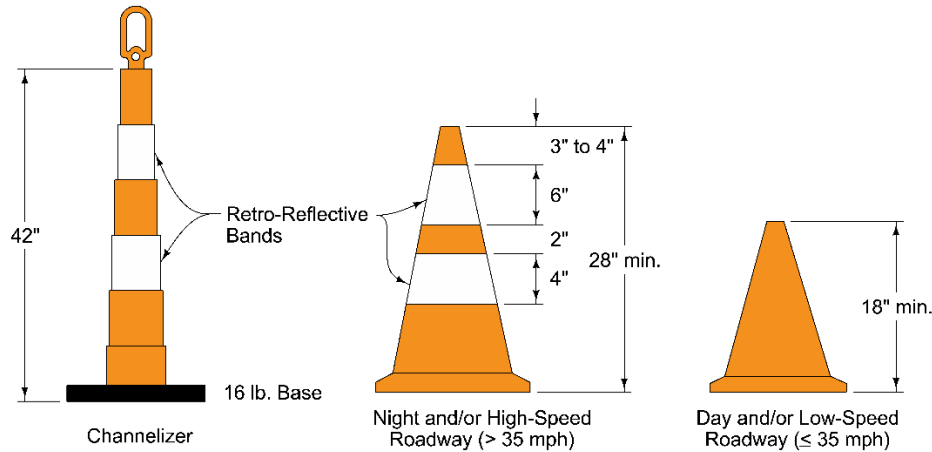

- b. **Tubular Markers:** Tubular markers have similar requirements as cones - predominantly orange, crashworthy, and retroreflective if used at night. Because of the narrow width (2 inch minimum), tubular markers are especially useful in restricted work areas. These devices must be securely ballasted or attached to the road surface to prevent movement.

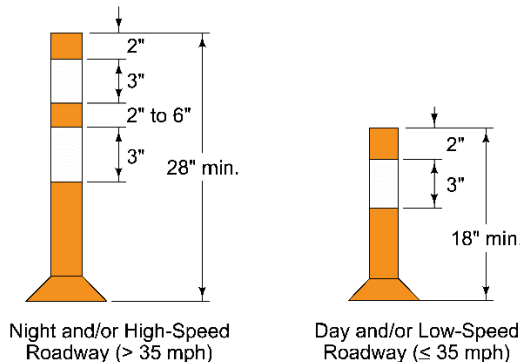

- c. **Vertical Panels:** Vertical panels provide greater visibility for road users than some other channelizing devices and can still be used in narrow work zone applications. Panels shall also have alternating retroreflective orange and white stripes, 4 or 6 inches wide, sloping downward at an angle of 45 degrees in the direction vehicular traffic is to pass. If warning lights are used with vertical panels, they must be securely fastened to prevent dislodging if struck by an errant vehicle. Proper ballasting should be used to maintain stability.

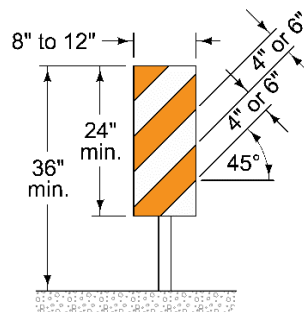

- d. Drums:** Drums are very effective traffic control devices, especially for long-term applications. These devices shall be made with lightweight, deformable materials and alternating 4 to 6 inch wide orange and white retroreflective stripes. Drums made of metal are not allowed, and tops shall be securely fastened to prevent accumulation of debris. Using ballast on top of drums is not acceptable.

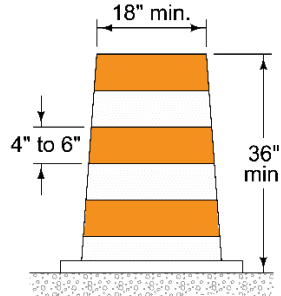

- e. Barricades:** Barricades for work zone applications are available in three types: I, II, and III, differentiated primarily by the number of boards used. Barricades may be used individually or in groups to mark a specific condition. They may also be used in a channelization series, in either taper or tangent applications.

Type I barricades are generally used on conventional roads or city streets. Type I or Type II barricades are intended for work areas where traffic flow is maintained. Type II or Type III barricades are recommended on higher volume roadways. Type III barricades should be used to close or partially close a street or road. For complete closures, Type III barricades can be extended across the entire roadway or street or supplemented with fencing.

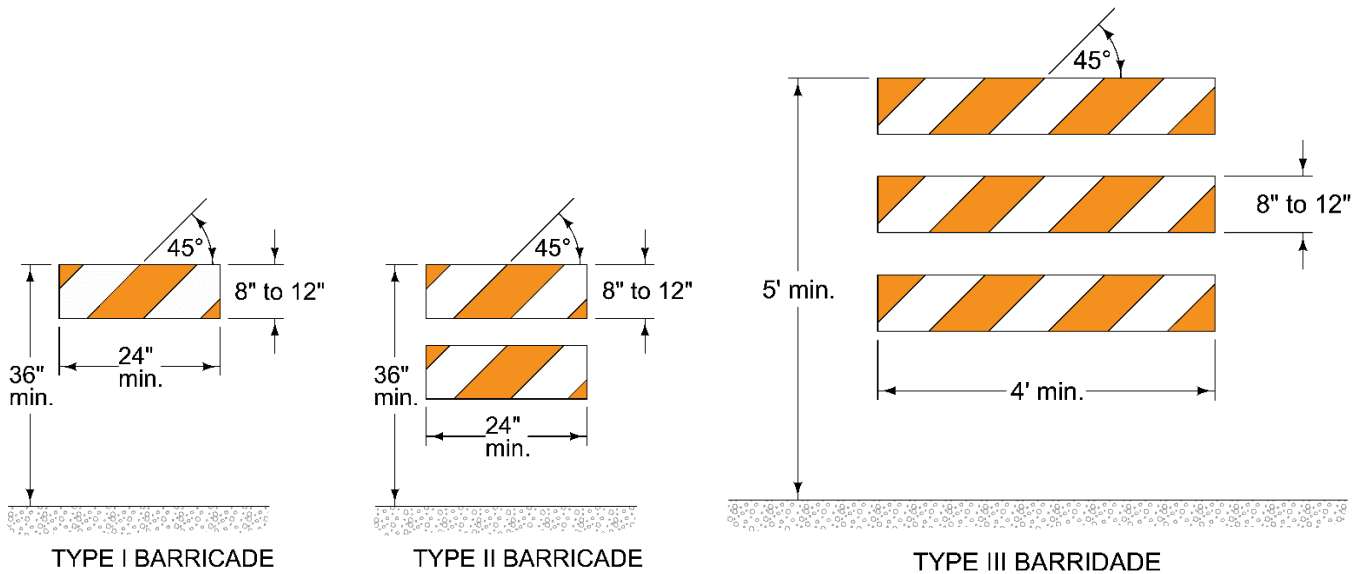

Using ballast, rocks, or broken concrete on top of barricades for stabilization is not allowed. Barricade rails shall feature alternating retroreflective orange and white stripes, 4 to 6 inches wide, sloping downward at a 45 degree angle in the direction traffic is expected to pass. As with vertical panels, properly placing the barricades is very important. If traffic is allowed to pass Type III barricades, retroreflective striping at the appropriate slope is required on both sides.

f. **Miscellaneous Devices for Channelizing:** The MUTCD describes several other devices that can be used in channelization of vehicular and pedestrian traffic in work zones.

1) **Arrow Boards:** As described in MUTCD Section 6F.61, arrow boards are signs with lighted elements capable of flashing or sequential displays. They are intended to be used with signs or other traffic control devices. The panels are rectangular and non-reflective black with yellow lights. The types of arrow boards used for temporary traffic control are:

- Type A: Suitable for low-speed urban streets
- Type B: Used on intermediate speed roadways or for maintenance and mobile operations
- Type C: Used for high-speed and high-volume applications

Table 13B-2.03: Minimum Requirements by Board Type

Board Type	Board Size	Legibility Distance	Number of Elements
A	48 x 24 inches	1/2 mile	12
B	60 x 30 inches	3/4 mile	13
C	96 x 48 inches	1 mile	15

Arrow boards can be mounted in various ways, but they should be mounted at least 7 feet above the ground, except on vehicle-mounted arrow boards, which should be as high as practical. Amber, high-intensity, rotating, flashing, oscillating, or strobe lights are required when panels are mounted on vehicles. Boards shall be able to dim 50% for night operations.

A caution mode is only allowed for two-lane or shoulder applications. The MUTCD does not allow a single arrow board to close more than one lane at a time.

Examples of the advance warning arrow board displays are below. Note right arrow is shown; left is similar.



Flashing Arrow (Merge Right)



Sequential Arrow (Merge Right)



Sequential Chevron (Merge Right)



Flashing Double Arrow (Merge Right or Left)



Flashing Caution

Flashing Caution

Alternating Diamond Caution

- 2) **Portable Changeable Message Sign (PCMS):** These devices have become more common in work zones on high-volume and high-speed roadways. A PCMS has a message panel, control system, power source, and transporting unit. Requirements and guidance for using these devices is presented in MUTCD Section 6F.60, and these provisions should be closely reviewed before using a PCMS. Effectiveness of a PCMS depends on how well drivers perceive and react to this device. Therefore, message visibility, length, clarity, and location to work activities are all critical for getting the most benefit from these devices. Current PCMS designs are not crashworthy, so place the devices off the roadway or behind a barrier.
- 3) **Shadow Vehicles:** Shadow vehicles, equipped with two amber, high-intensity, rotating, flashing, oscillating, or strobe lights mounted on the rear of the vehicle, can be used to warn traffic of the operation ahead. The distance between the work vehicle and the shadow vehicle may vary according to terrain, type of work, or other factors. Whenever adequate stopping sight distance exists, the shadow vehicle should maintain the minimum distance to the work vehicle and proceed at the same speed. The shadow vehicle should slow down in advance of vertical or horizontal curves that restrict sight distance. The work and shadow vehicle should pull over periodically to allow traffic to pass. When an adequate shoulder is present, the shadow vehicle should use it for travel. If the work and shadow vehicle cannot pull over to allow traffic to pass, a DO NOT PASS (R4-1) sign may be placed on the shadow vehicle.