Open Channel Flow

A. Introduction

The beginning of any channel design or modification is to understand the hydraulics of the stream. The procedures for performing uniform flow calculations aid in the selection or evaluation of appropriate depths and grades for natural or man-made channels. Allowable velocities are provided, along with procedures for evaluating channel capacity using Manning's equation.

All the methods described herein will be based on the conservation of mass, momentum and energy (in the form of Bernoulli's theorem), and the Manning formula for frictional resistance. Steady uniform flow and steady non-uniform flow are the types of flow addressed in this section.

B. Definitions

Critical Flow: The variation of specific energy with depth at a constant discharge shows a minimum in the specific energy at a depth called critical depth at which the Froude number has a value of one. Critical depth is also the depth of maximum discharge, when the specific energy is held constant.

Froude Number: The Froude number is an important dimensionless parameter in open-channel flow. It represents the ratio of inertia forces to gravity forces. This expression for Froude number applies to any single-section channel of nonrectangular shape.

Hydraulic Jump: Hydraulic jumps occur at abrupt transitions from supercritical to subcritical flow in the flow direction. There are significant changes in the depth and velocity in the jump, and energy is dissipated. For this reason, the hydraulic jump is often employed to dissipate energy and control erosion at stormwater management structures.

Kinetic Energy Coefficient: As the velocity distribution in a river varies from a maximum at the design portion of the channel to essentially zero along the banks, the average velocity head.

Normal Depth: For a given channel geometry, slope, and roughness, and a specified value of discharge Q , a unique value of depth occurs in a steady uniform flow. It is called the normal depth. The normal depth is used to design artificial channels in a steady, uniform flow and is computed from Manning's equation.

Specific Energy: Specific energy (E) is the energy head relative to the channel bottom. If the channel is not too steep (slope less than 10%), and the streamlines are nearly straight and parallel (so that the hydrostatic assumption holds), the specific energy E becomes the sum of the depth and velocity head. The kinetic energy correction coefficient is taken to have a value of one for turbulent flow in prismatic channels but may be significantly different from one in natural channels.

Steady and Unsteady Flow: A steady flow is when the discharge passing a given cross-section is constant with respect to time. When the discharge varies with time, the flow is unsteady. The maintenance of steady flow requires that the rates of inflow and outflow be constant and equal.

Subcritical Flow: Depths of flow greater than critical depths, resulting from relatively flat slopes. Froude number is less than one. Flow of this type is most common in flat streams.

Supercritical Flow: Depths of flow less than critical depths resulting from relatively steep slopes. Froude number is greater than one. Flow of this type is most common in steep streams.

Total Energy Head: The total energy head is the specific energy head plus the elevation of the channel bottom with respect to some datum. The curve of the energy head from one cross-section to the next defines the energy grade line.

Uniform Flow and Non-uniform Flow: A non-uniform flow is one in which the velocity and depth vary over distance, while they remain constant in uniform flow. Uniform flow can occur only in a channel of constant cross-section, roughness, and slope in the flow direction; however, non-uniform flow can occur in such a channel or in a natural channel with variable properties.

C. Uniform Flow (Manning's Equation)

- 1. Manning's Equation:** The normal depth is used to design artificial channels in a steady, uniform flow and is computed from Manning's equation:

$$Q = AV = \frac{1.486}{n} (AR^{2/3}) (s^{1/2}) \quad \text{Equation 2F-2.01}$$

where:

V = Channel velocity, ft/s (see Tables 2F-2.03 and 2F-2.04 for permissible velocities)

Q = Discharge, cfs

A = Cross-sectional area of flow, ft²

n = Manning's roughness coefficient (see [Section 2B-3](#))

R = hydraulic radius, ft = A/P

P = wetted perimeter, ft

s = slope of hydraulic grade line (pipe/channel slope), ft/ft

The selection of Manning's n is generally based on observation; however, considerable experience is essential in selecting appropriate n values. If the normal depth computed from Manning's equation is greater than critical depth, the slope is classified as a mild slope, while on a steep slope, the normal depth is less than critical depth. Thus, uniform flow is subcritical on a mild slope and supercritical on a steep slope.

Strictly speaking, uniform flow conditions seldom, if ever, occur in nature because channel sections change from point to point. For practical purposes in highway engineering, however, the Manning equation can be applied to most streamflow problems by making judicious assumptions. When the requirements for uniform flow are met, the depth (d_n) and the velocity (V_n) are said to be normal and the slopes of the water surface and channel are parallel. For practical purposes, in open channel design, minor undulations in streambed or minor deviations from the mean (average) cross-section can be ignored as long as the mean slope of the channel can be represented as a straight line. The Manning equation can readily be solved either graphically or mathematically for the average velocity in a given channel if the normal depth is known, because the various factors in the equation are known or can be determined (the hydraulic radius can be computed from the normal depth in a given channel). Discharge (Q) is then the product of the velocity and the area of flow (A).

2. **Continuity Equation:** The continuity equation is the statement of conservation of mass in fluid mechanics. For the special case of steady flow of an incompressible fluid, it assumes the simple form:

$$Q = A_1 V_1 = A_2 V_2 \quad \text{Equation 2F-2.02}$$

where:

A = flow cross-sectional area, ft²

V = mean cross-sectional velocity, ft/s (measured perpendicular to cross-section)

The subscripts 1 and 2 refer to successive cross-sections along the flow path. The continuity equation can be used with Manning's equation to obtain steady uniform flow velocity as:

$$V = \frac{Q}{A} = \frac{1.49 \left(R^{2/3} \right) \left(A^{1/2} \right)}{n} \quad \text{Equation 2F-2.03}$$

D. Energy Flow

Flowing water contains energy in two forms, potential and kinetic. The potential energy at a particular point is represented by the depth of the water plus the elevation of the channel bottom above a convenient datum plane. The kinetic energy, in feet, is represented by the velocity head:

$$\text{Kinetic energy} = \frac{v^2}{2g} \quad \text{Equation 2F-2.04}$$

In channel flow problems it is often desirable to consider the energy content with the channel bottom. This is called the specific energy or specific head and is equal to the depth of water plus the velocity head:

$$\text{Specific energy} = d + \frac{v^2}{2g} \quad \text{Equation 2F-2.05}$$

At other times it is desirable to use the total energy content (total head), which is the specific head plus the elevation of the channel bottom above a selected datum. For example, total head may be used in applying the energy equation, which states that the total head (energy) at one point in a channel carrying a flow of water is equal to the total head (energy) at any point downstream plus the energy (head) losses occurring between the two points. The energy (Bernoulli) equation is usually written:

$$d_1 + \frac{V_1^2}{2g} + Z_1 = d_2 + \frac{V_2^2}{2g} + Z_2 + h_{loss} \quad \text{Equation 2F-2.06}$$

In this equation, cross-section 2 (subscript 2) is downstream from cross-section 1 (subscript 1), Z is the elevation of channel bottom, and h_{loss} represents loss of head between cross-sections 1 and 2. A convenient way of showing specific head is to plot the water surface and the specific head lines above a profile of the channel bottom (see Figure 2F-2.01).

Note in Figure 2F-2.01 that the line obtained by plotting velocity head above the water surface is the same line as that obtained by plotting specific head above the channel bottom. This line represents the total energy, potential and kinetic, of the flow in the channel, and is called the "total head line" or "total energy line."

The slope (gradient) of the energy line is a measure of the friction slope or rate of energy head loss due to friction. Under uniform flow, the energy line is parallel to the water surface and to the streambed. For flow to occur in a channel, the total head or energy line must slope negatively (downward) in the direction of flow.

Figure 2F-2.01: Channel Flow Terms

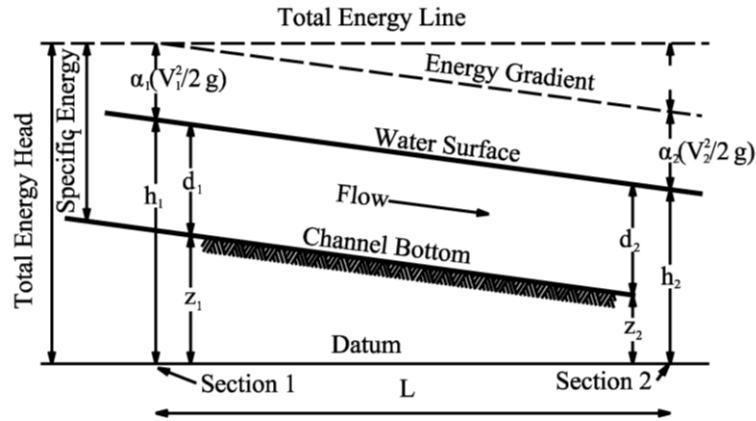
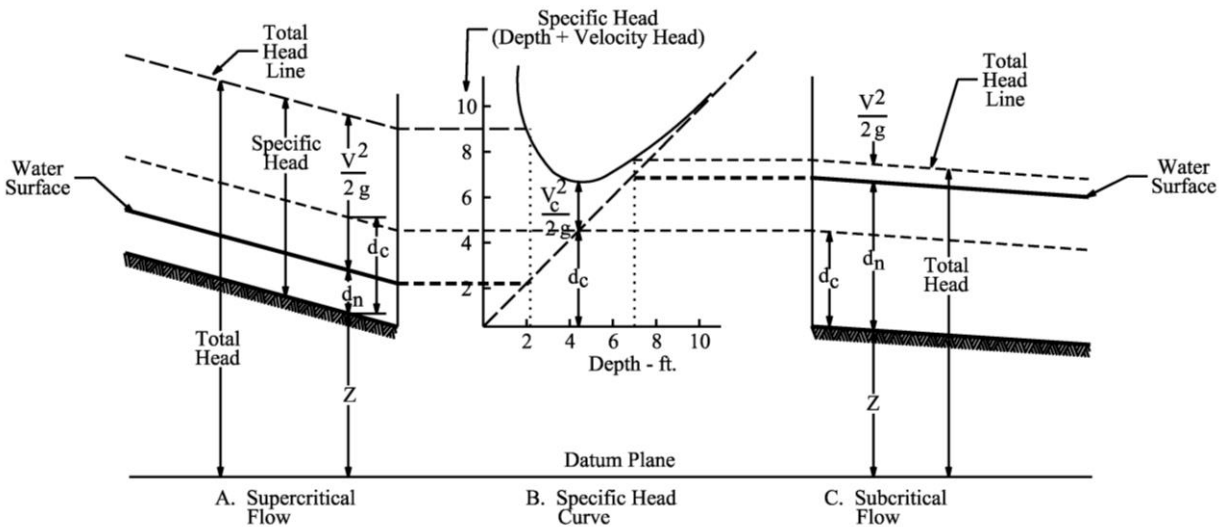

Figure 2F-2.02: Definition Sketch of Specific Head



Source: *Design Charts for Open-Channel Flow*, FHWA

- Critical Flow:** The relative values of the potential energy (depth) and the kinetic energy (velocity head) are important in the analysis of open-channel flow. Consider, for example, the relation of the specific head, $d + \frac{V^2}{2g}$, and the depth of a given discharge in a given channel that can be placed on various slopes. Plotting values of specific head as ordinates and of the corresponding depth as abscissa will result in a specific-head curve such as that shown in Figure 2F-2.02. The straight diagonal line is drawn through points where depth and specific head are equal. The line thus represents the potential energy, and the ordinate interval between this line and the specific head curve is the velocity head for the particular depth. A change in the discharge or in the channel size or shape will change the position of the curve, but its general shape and location above and to the left of the diagonal line will remain the same.

Note that the ordinate at any point on the specific head curve represents the total specific energy at that point. The lowest point on the curve represents flow with the minimum energy content. The depth at this point is known as critical depth (d_c) and the corresponding velocity is the critical velocity (V_c). With uniform flow, the channel slope at which critical depth occurs is known as the critical slope (S_c). The magnitude of critical depth depends only on the discharge and the shape of the channel, and is independent of the slope or channel roughness. Thus, in any given size and shape of channel, there is only one critical depth for a particular discharge. Critical depth is an important value in hydraulic analysis because it is a control in reaches of non-uniform flow whenever the flow changes from subcritical to supercritical.

Typical occurrences of critical depths are:

- a. Entrance to a restrictive channel, such as a culvert or flume, on a steep slope
- b. At the crest of an overflow dam or weir
- c. At the outlet of a culvert or flume discharging with a free fall or into a relatively wide channel or a pond in which the depth is not enough to submerge critical depth in the culvert or flume.

2. Critical Depth Calculations:

- a. The general equation for determining critical depths on the discharge rate and channel geometry is:

$$\frac{Q^2}{g} = \frac{A^3}{T}$$

Equation 2F-2.07

where:

g = acceleration of gravity, ft/s² (32.2)

A = cross-sectional area, ft²

T = top width of water surface, ft

A trial and error procedure is needed to solve Equation 2F-2.07. The following guidelines are presented for evaluating critical flow conditions of open channel flow:

- 1) A normal depth of uniform flow within about 10% of critical depth is unstable (relatively large depth changes are likely for small changes in roughness, cross-sectional area, or slope) and should be avoided in design, if possible.
- 2) If the velocity head is less than one-half the mean depth of flow, the flow is subcritical.
- 3) If the velocity head is equal to one-half the mean depth of flow, the flow is critical.
- 4) If the velocity head is greater than one-half the mean depth of flow, the flow is supercritical.
- 5) If an unstable critical depth cannot be avoided in design, the least favorable type of flow should be assumed for the design.

- b. The Froude number, Fr , calculated by the flowing equation, is useful for evaluating the type of flow conditions in an open channel:

$$Fr = \frac{V}{\left(\frac{gA}{T}\right)^{1/2}} \quad \text{Equation 2F-2.08}$$

where:

- Fr = Froude number (dimensionless)
 V = velocity of flow, ft/s
 g = acceleration of gravity, ft/s² (32.2)
 T = top width of flow, ft

If Fr is greater than 1.0, flow is supercritical; if it is under 1.0, flow is subcritical. Fr is 1.0 for critical flow conditions.

3. **Critical Slope:** Critical slope is that channel slope for a particular channel and discharge, at which the normal depth for uniform flow will be the same as the critical depth. Critical slope varies with both the roughness and geometric shape of the channel and with the discharge. For large circular cross-section pipes, and for pipe-arch and oval pipe sections, a direct reading can be made on the part-full flow charts for critical depth, specific head, and critical slope (for certain values of n).
4. **Supercritical Flow:** Points on the left of the flow point of the specific head curve [Figure 2F-2.02 (B)] are for channel slopes steeper than critical (supercritical or steep slopes), and indicate relatively shallow depths and high velocities [Figure 2F-2.02 (A)]. Such flow is called supercritical flow. It is difficult to handle because violent wave action occurs when either the direction of flow or the cross-section is changed. Flow of this type is common in steep streams. In supercritical flow, the depth of flow at any point is influenced by a control upstream, usually critical depth.
5. **Subcritical Flow:** Points on the right of the low point of the specific head curve [Figure 2F-2.02 (B)] are for slopes flatter than critical (subcritical or mild slopes) and indicate relatively large depths with low velocities [Figure 2F-2.02 (C)]. Such flow is called subcritical flow. It is relatively easy to handle through transitions because the wave actions are tranquil. In subcritical flow, the depth at any point is influenced by a downstream control, which may be either critical depth or the water surface elevation in a pond or larger downstream channel. Figures 2F-2.02 (A) and 2F-2.02 (C) indicate the relationship of supercritical and subcritical flows, respectively, to the specific head curve.

E. Non-uniform Flow

Flow that varies in depth and velocity along the channel is called non-uniform. Truly uniform flow rarely exists in either natural or man-made channels, because changes in channel section, slope, or roughness cause the depths and average velocities of flow to vary from point to point along the channel, and the water surfaces will not be parallel to the streambed. Although moderate non-uniform flow actually exists in a generally uniform channel, it is usually treated as uniform flow in such cases. Uniform flow characteristics can readily be computed and the computed values are usually close enough to the actual for all practical purposes. The types of non-uniform flow are innumerable, but certain characteristic types are more common.

With subcritical flow, a change in channel shape, slope, or roughness affects the flow for a considerable distance upstream, and thus the flow is said to be under downstream control. If an obstruction, such as a culvert, causes ponding, the water surface above the obstruction will be a smooth curve asymptotic to the normal water surface upstream and to the pool level downstream (see Figure 2F-2.03).

Another example of downstream control occurs where an abrupt channel enlargement, as at the end of a culvert not flowing full, or a break in grade from a mild to a steep slope, causes a drawdown in the flow profile to critical depth. The water surface profile upstream from a change in section or a break in channel slope will be asymptotic to the normal water surface upstream, but will drop away from the normal water surface on approaching the channel change or break in slope. In these two examples, the flow is non-uniform because of the changing water depth caused by changes in the channel slope or channel section. Direct solution of open-channel flow by the Manning equation or by the charts in this section is not possible in the vicinity of the changes in the channel section or channel slope. With supercritical flow, a change in the channel shape, slope, or roughness cannot be reflected upstream except for very short distances. However, the change may affect the depth of flow at downstream points; thus, the flow is said to be under upstream control.

Most problems in highway drainage do not require the accurate computation of water surface profiles. However, the designer should know that the depth in a given channel may be influenced by conditions either upstream or downstream, depending on whether the slope is steep (supercritical) or mild (subcritical).

Figure 2F-2.03 shows a channel on a mild slope, discharging into a pool. The vertical scale is exaggerated to illustrate the case more clearly. Cross-section 1 is located at the end of uniform channel flow in the channel and cross-section 2 is located at the beginning of the pool. Depth 2 is located at the beginning of the pool. The depth of flow (d) between sections 1 and 2 is changing and the flow is non-uniform. The water surface profile between the sections is known as backwater curve and is characteristically very long.

Figure 2F-2.03: Water Surface Profile in Flow from a Channel to a Pool

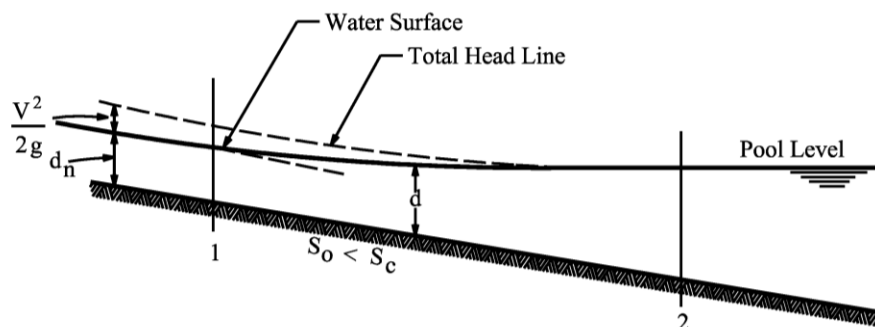

Source: *Design Charts for Open-Channel Flow*, FHWA

Figure 2F-2.04 shows a channel in which the slope changes from subcritical to supercritical. The flow profile passes through critical depth near the break in slope (section 1). This is true whether the upstream slope is mild, as in the sketch, or whether the water above section 1 is ponded, as would be the case if section 1 were the crest of the spillway of a dam. If, at section 2, the total head were computed, assuming normal depth on the steep slope, it would plot (point a on the sketch) above the elevation of the total head at section 1. This is physically impossible, because the total head line must slope downward in the direction of flow. The actual total head line will take the position shown, and have a slope approximately equal to S_c at section 1 and approaching slope S_0 farther downstream. The drop in the total head line h_f between sections 1 and 2 represents the loss in energy due to

friction. At section 2 the actual depth d_2 is greater than d_n because sufficient acceleration has not occurred and the assumption of normal depth at this point would clearly be in error. As section 2 is moved downstream so that total head for the normal depth drops below the pool elevation above section 1, the actual depth quickly approaches the normal depth for the steep channel. This type of water surface curve (section 1 to section 2) is characteristically much shorter than the backwater curve discussed in the previous paragraph.

Another common type of non-uniform flow is the drawdown curve to critical depth which occurs upstream from section 1 (Figure 2F-2.04) where the water surface passes through the critical depth. The depth gradually increases upstream from critical depth to normal depth, provided the channel remains uniform through a sufficient length. The length of the drawdown curve is much longer than the curve from critical depth to normal depth in a steep channel.

Figure 2F-2.04: Water Surface Profile in Changing from Subcritical to Supercritical Channel Slope

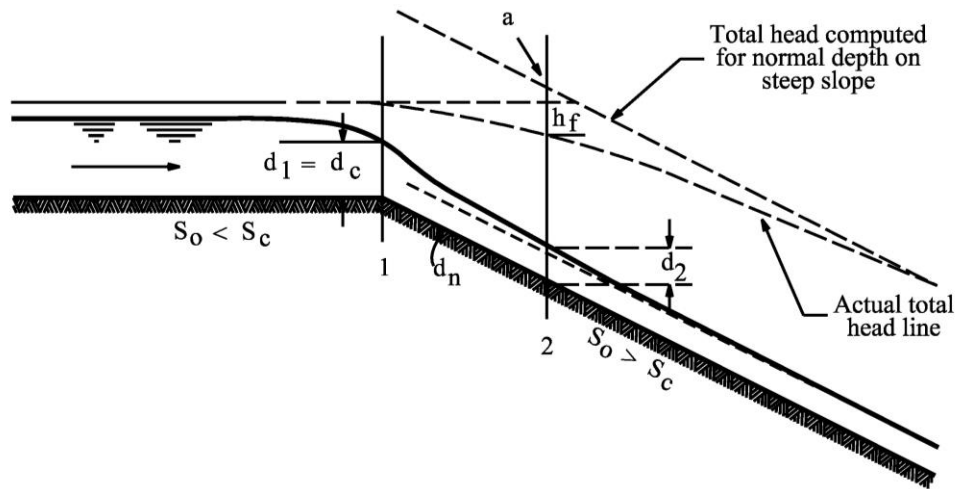

Source: *Design Charts for Open-Channel Flow*, FHWA

Figure 2F-2.05 shows a special case for a steep channel discharging into a pool. A hydraulic jump makes a dynamic transition from the supercritical flow in a pool. This situation differs from that shown in Figure 2F-2.03 because the flow approaching the pool in Figure 2F-2.05 is supercritical and the total head in the approach channel is large relative to the pool depth. In general, the supercritical flow can be changed to subcritical flow only by passing through a hydraulic jump. The violent turbulence in the jump dissipates energy rapidly, causing a sharp drop in the total head line between the supercritical and subcritical states of flow. A jump will occur whenever the ratio of the depth d_1 in the approach channel to the depth d_2 in the downstream channel reaches a specific value. Note in Figure 2F-2.05 that normal depth in the approach channel persists well beyond the point where the projected pool level would intersect the water surface of the channel at normal depth. Normal depth can be assumed to exist on the steep slope upstream from section 1, which is located about at the toe of the jump.

Figure 2F-2.05: Water Surface Profile Illustrating Hydraulic Jump

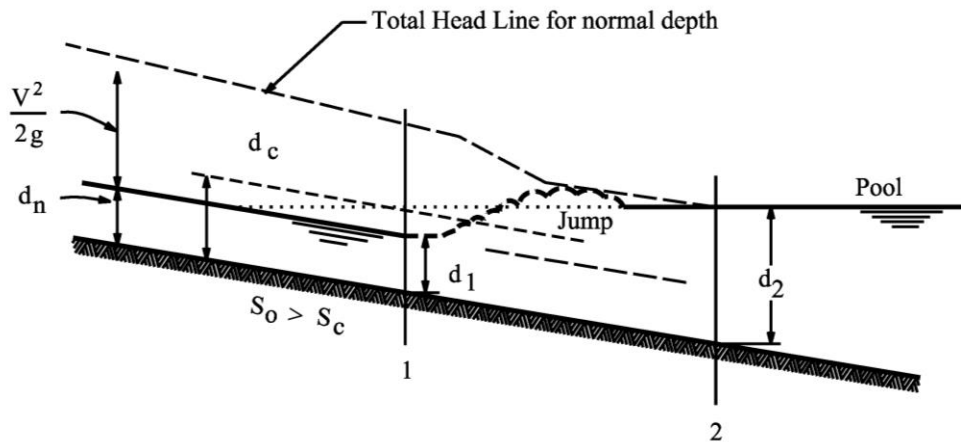

Source: *Design Charts for Open-Channel Flow*, FHWA

F. Hydraulic Jump

1. **General:** The hydraulic jump consists of an abrupt rise of the water surface in the region of impact between rapid and tranquil flows. Flow depths before (supercritical depth, d_1) and after (subcritical depth, d_2) the jump are less than and greater than critical depth, respectively. The depth d_1 is calculated based on the hydraulics of the channel. The depth d_2 is calculated as shown in part 2. The zone of impact of the jump is accompanied by large-scale turbulence, surface waves, and energy dissipation. The hydraulic jump in a channel may occur at locations such as:
 - a. The vicinity of a break in grade where the channel slope decreases from steep to mild.
 - b. A short distance upstream from channel constrictions such as those caused by bridge piers.
 - c. A relatively abrupt converging transition.
 - d. A channel junction where rapid flow occurs in a tributary channel and tranquil flow in the main channel.
 - e. Long channels where high velocities can no longer be sustained on a mild slope.

Figure 2F-2.06: Hydraulic Jump and Depth of Flow

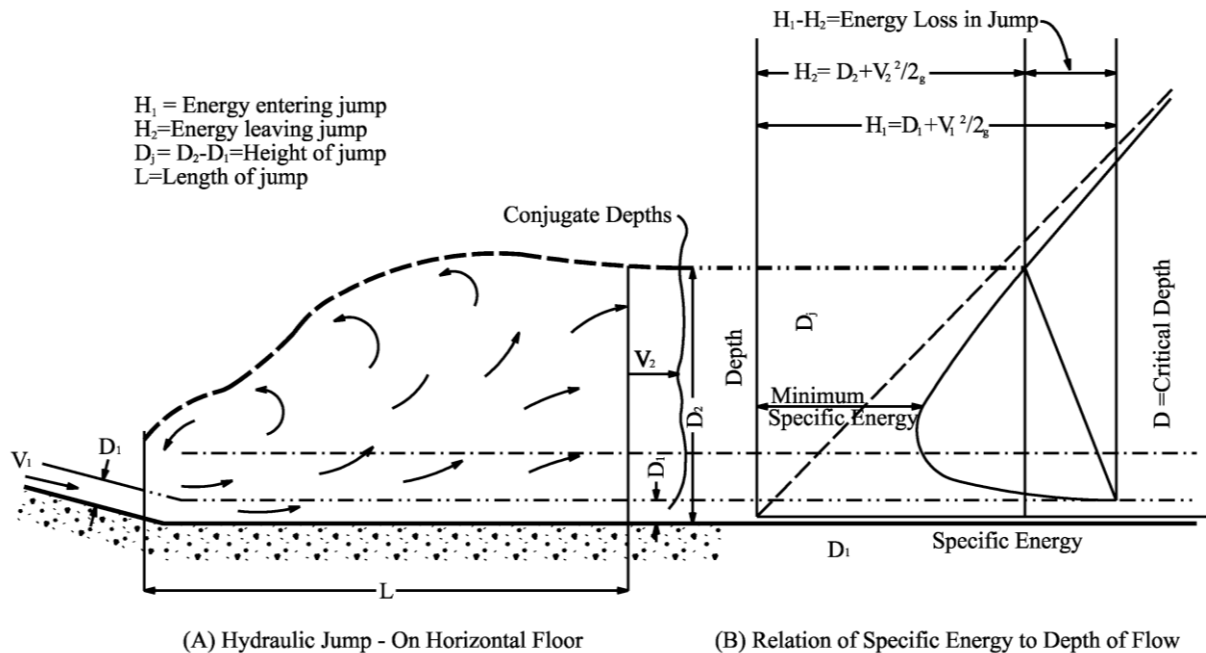

2. Hydraulic Jump Computations: The method for calculating the length of the hydraulic jump and the resulting flow depth and velocity downstream of the jump is discussed in detail in FHWA’s Hydraulic Engineering Circular No. 14 (HEC-14), Hydraulic Design of Energy Dissipators for Culverts and Channels. Due to the complex energy calculations required to analyze hydraulic jumps, the use of appropriate hydraulic design software is encouraged.

Table 2F-2.03: Permissible Velocities for Channels with Erodible Linings, Based on Uniform Flow in Continuously Wet, Aged Channels

| Soil Type or Lining (earth; no vegetation) | Maximum Permissible Velocities for... | | |
|---|--|---------------------------------------|--|
| | Clear Water (fps) | Water Carrying Fine Silts (fps) | Water Carrying Sand and Gravel (fps) |
| Fine sand (non-colloidal) | 1.5 | 2.5 | 1.5 |
| Sandy loam (non-colloidal) | 1.7 | 2.5 | 2.0 |
| Silt loam (non-colloidal) | 2.0 | 3.0 | 2.0 |
| Ordinary firm loam | 2.5 | 3.5 | 2.2 |
| Volcanic ash | 2.5 | 3.5 | 2.0 |
| Fine gravel | 2.5 | 5.0 | 3.7 |
| Stiff clay | 3.7 | 5.0 | 3.0 |
| Graded, loam to cobbles (non-colloidal) | 3.7 | 5.0 | 5.0 |
| Graded, silt to cobbles (colloidal) | 4.0 | 5.5 | 5.0 |
| Alluvial silts (non-colloidal) | 2.0 | 3.5 | 2.0 |
| Alluvial silts (colloidal) | 3.7 | 5.0 | 3.0 |
| Coarse gravel (non-colloidal) | 4.0 | 6.0 | 6.5 |
| Cobbles and shingles | 5.0 | 5.5 | 6.5 |
| Shales and hard pans | 6.0 | 6.0 | 5.0 |
| Fabric and excelsior mat | 7.0 | 7.0 | 7.0 |
| Dry rip rap/gabions | 10.0 | 10.0 | 10.0 |
| Concrete pilot channel | Use grass permissible velocity - Table 2F-2.04 | | |

Table 2F-2.04: Permissible Velocities for Channels Lined with Uniform Stands of Various Grass Covers, Well Maintained¹

| Cover | Slope Range (percent) | Permissible Velocity on... | |
|--|--------------------------|--|--------------------------------------|
| | | <i>Erosion Resistant Soils (fps)</i> | <i>Easily Eroded Soils (fps)</i> |
| Bermudagrass | 0 to 5 | 8 | 6 |
| | 5 to 10 | 7 | 5 |
| | Over 10 | 6 | 4 |
| Buffalograss Kentucky bluegrass Smooth brome Blue grama | 0 to 5 | 7 | 5 |
| | 5 to 10 | 6 | 4 |
| | Over 10 | 5 | 3 |
| Grass mixture | 0 to 5 | 5 | 4 |
| | 5 to 10 | 4 | 3 |
| Lespedeza sericea Weeping lovegrass Yellow bluestem Kudzu Alfalfa Crabgrass | 0 to 5 | 3.5 | 2.5 |
| Common lespedeza ² Sudangrass | 0 to 5 ³ | 3.5 | 2.5 |

¹ Use velocities of 5 fps only where good covers and proper maintenance can be obtained.

² Annuals, used on mild slopes or as temporarily protection until permanent covers are established.

³ Use on slopes steeper than 5% is not recommended.

Source: From *Handbook of Channel Design for Soil and Water Conservation*

G. References

U.S. Department of Transportation. *Design Charts for Open-Channel Flow*. Hydraulic Design Series No. 3. 1961.

U.S. Soil Conservation Service. *Handbook of Channel Design for Soil and Water Conservation*. 1947.