



Table of Contents

Chapter 8 - Parking Lots

8A General Information

8A-1-----General Information	
A. General.....	1
B. References.....	1

8B Layout and Design

8B-1-----Layout and Design	
A. Parking Lot Access.....	1
B. Parking Lot Circulation.....	1
C. Parking Lot Dimensions.....	2
D. Accessibility Requirements.....	5
E. Drainage.....	7
F. Pavement Design.....	8

8C Site Provisions

8C-1-----Site Provisions	
A. General.....	1
B. Number of Parking Spaces Required.....	1
C. Parking Lot Setback Requirements.....	4
D. Landscaping and Screening.....	4
E. Lighting.....	6
F. Pavement Markings.....	6

General Information

A. General

This chapter provides design criteria for off-street parking lots. These criteria include recommendations for the design of entrances and exits, vehicle circulation path, parking space dimensions, pavement thickness, etc. This chapter also includes site requirements for items such as number of parking spaces, landscaping, parking setback, etc.

While most jurisdictions have their own parking ordinance covering these items, they are included here as guidance for those communities that do not have a parking ordinance. This information may also be used as a supplement to existing parking ordinances.

B. References

The design for parking lot facilities should comply with the current edition of the following:

Urban Land Institute (ULI) & National Parking Association (NPA), *The Dimensions of Parking*

US Department of Justice. *2010 ADA Standards for Accessible Design*.

Layout and Design

A. Parking Lot Access

Properly designed parking lot access provides for safe and efficient movement of vehicles into and out of the parking lot. Refer to [Chapter 5 - Roadway Design](#) for additional information on access management and driveway design, spacing, and location selection.

The most efficient approach to designing parking lot access places a priority on moving inbound traffic from the public roadway into the facility. Entrances should be located on major streets, align with interior traffic lanes/aisles, and direct inbound traffic toward the destination. Traffic control within the lot should provide inbound traffic the right-of-way. Favoring inbound traffic expedites the rapid movement of vehicles from the street into the facility and prevents vehicles from lining up on public roadways. Where a high volume parking lot is adjacent to a high volume or high speed roadway, a dedicated deceleration/turning lane at the entrance helps eliminate rear-end accidents.

Exits should be located away from the destination point and discharge vehicles onto lower volume adjacent side streets if possible. Since exiting traffic tends to move more slowly, drivers can more comfortably navigate the turns required to reach the exit. Vehicles queued to exit the parking lot will stack up inside the lot and will not affect traffic on the public street.

Where separate entrances and exits cannot be provided, the driveway to the parking lot should be at least 24 feet wide to provide two 12 foot lanes.

Traffic studies may be required for entrances to large retail centers, event facilities, or businesses with large numbers of employees entering or exiting the lot at the beginning or end of a work day or shift.

B. Parking Lot Circulation

Off-street parking lots should be designed to accommodate traffic volumes and pedestrian circulation based on the land use served. The use of islands, medians, curbing, and landscaping is encouraged to separate parking spaces from traffic and pedestrian circulation areas.

Parking spaces at entrance and exit points should be terminated (except at one and two family dwelling units) to prevent conflict between vehicles attempting to enter or exit the parking space, and vehicles attempting to enter or exit the parking lot.

Access between adjacent commercial parking lots should be considered. This allows patrons to travel from one business to the adjacent business without entering the public street and then turning immediately into the next parking area. These types of movements can cause operational problems on the public street.

C. Parking Lot Dimensions

1. **Parking Spaces:** In order to determine parking space sizes, the design vehicle size must be defined. Since 1999, the size of the 85th percentile vehicle on the road has varied slightly, but has remained within an inch or two of 6 feet, 7 inches wide by 17 feet, 3 inches long.

In addition to vehicle size, the designer must consider the intended function of the parking facility. For example, facilities with high turnover rates, such as convenience stores, should have greater clearances than those with low turnover rates. In addition, where a significant portion of users may be elderly, such as at hospitals, larger dimensions may be appropriate.

Parking spaces that provide sufficient clearance for doors to be opened and occupants to enter and exit will also provide adequate width for maneuvering if the adjacent aisle is wide enough. Door opening clearances should range from 23 inches in low turnover facilities to 27 inches in high turnover facilities. Table 8B-1.01 lists recommended parking stall widths on the basis of turnover.

Table 8B-1.01: Recommended Minimum Widths for Parking Stalls

Facility Type	Width
Low turnover (employees, students, etc)	8'-6"
Moderate to high turnover (retail, medical facilities, etc.)	9'-0"

Source: Urban Land Institute, National Parking Association

For stalls that are adjacent to walls, curbs, islands, or other obstructions, increase the stall width by at least 12 inches to allow for door opening and to reduce the risk of tripping.

Unlike width, the length of a parking space is not affected by turnover rate or user type. The recommended length of a parking space is 18 feet. The length of the parking space may be modified up to 2 feet, if vehicle overhang is allowed. However, the designer should be aware that the aerodynamic design of many current vehicles often does not provide sufficient vertical clearance for vehicles to pull forward over the curb.

2. **Parking Module Design:** The drive aisle is the space between two parking stalls directly across from one another. The term “module” refers to the width of the drive aisle combined with the length of the parking stalls on one or both sides of the drive aisle. Table 8B-1.02 lists recommended minimum dimensions for parking facilities. Figure 8B-1.01 provides further definition of the terms used in Table 8B-1.02.

The only dimension that varies by stall width is the interlock dimension. An interlock occurs with angled parking when two stalls in adjacent modules align. The overlap at the front of the stalls is the interlock dimension. When a parking facility is designed to take advantage of interlock, the effective width of the module may be reduced by the interlock dimension. For aisles with interlocking spaces on both sides, the effective width of the module may be reduced by two times the interlock distance. This approach can provide a more efficient parking lot facility and reduce the overall surface area required for the parking lot.

Because snow can obscure pavement markings, vehicles will often pull too far into a parking space, which reduces the width of the aisle in the adjacent module. This has been taken into consideration in Table 8B-1.02. Therefore, when a curb, wall, or other physical restraint is provided for on at least 30% of the stalls, the aisle width (and therefore the overall module width) may be reduced by 1 foot.

Table 8B-1.02: Minimum Parking Dimensions

Parking Lot Dimension			Parking Angle (θ)					
			Two-way Aisle			One-way Aisle		
			90°	60°	45°	60°	45°	
Stall Projection	SP	18'-0"	15'-7"	12'-9"	15'-7"	12'-9"		
Aisle Width	A	24'-0"	25'-10"	29'-8"	20'-4"	21'-6"		
Base Module	M ₁	60'-0"	57'-0"	55'-2"	51'-6"	47'-0"		
Single Loaded Module	M ₂	42'-0"	39'-0"	37'-7"	32'-6"	29'-5"		
Wall to Interlock	M ₃	60'-0"	55'-10"	52'-2"	49'-4"	44'-0"		
Interlock to Interlock	M ₄	60'-0"	53'-8"	49'-2"	47'-2"	41'-0"		
Overhang	o	2'-6"	2'-2"	1'-9"	2'-2"	1'-9"		
Stall Width	8'-6"	Width Projection	WP	8'-6"	9'-10"	12'-0"	9'-10"	12'-0"
		Interlock	i	0'-0"	2'-2"	3'-0"	2'-2"	3'-0"
	9'-0"	Width Projection	WP	9'-0"	10'-5"	12'-9"	10'-5"	12'-9"
		Interlock	i	0'-0"	2'-3"	3'-2"	2'-3"	3'-2"

Notes:

1. Aisle width may be increased up to 3 feet to provide a higher level of comfort.
2. In lots where at least 30% of stalls have curbs, aisle width may be reduced by 1'-0".
3. Light poles and columns may protrude a maximum of 2 feet into a parking module as long as they do not encroach on more than 30% of the stalls. When more than 30% of the stalls are encroached, interlock reductions cannot be taken.
4. For additional parking angles, refer to The Dimensions of Parking, ULI, NPA

Source: Adapted from Urban Land Institute, National Parking Association

Perpendicular parking provides the greatest number of parking spaces for a given a length of aisle. One-way angled parking provides fewer spaces than perpendicular for the same length of aisle, but has the advantage of a narrower drive aisle. Because of this, the surface area per parking space for perpendicular and angled one-way parking is approximately equal.

Two-way angled parking is also allowable and can be useful in certain situations; however, it is a less efficient design than two-way perpendicular or one-way angled parking. Two-way angled parking cannot take full advantage of the narrower drive aisle, requiring approximately 10% to 15% more area per parking space than perpendicular or one-way angled parking.

Figure 8B-1.01: Parking Dimensions

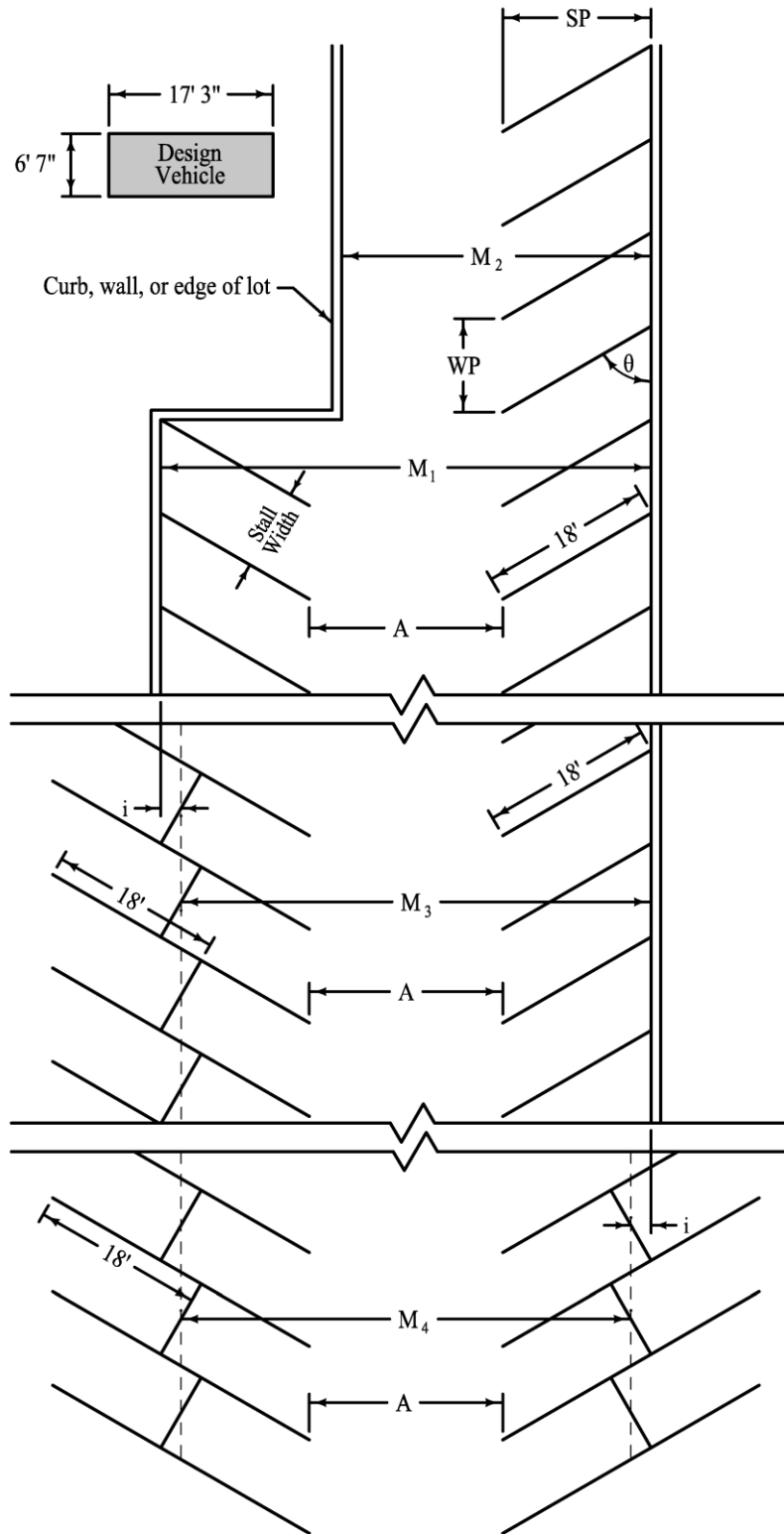

SP = Stall Projection
 A = Aisle Width
 WP = Width Projection
 i = Interlock

M₁ = Base Module (2SP + A)
 M₂ = Single Loaded Module (SP + A)
 M₃ = Wall to Interlock (M₁ - i)
 M₄ = Interlock to Interlock (M₁ - 2i)

3. **Compact Parking:** It is no longer recommended that compact car only spaces be provided. At the time when compact car parking spaces were introduced, the mix of automobiles consisted of clearly defined very large and very small vehicles. As a result, the use of compact parking only was largely self enforcing; however, the current mix of automobile sizes is much more diverse. There is no longer a clear definition among the public of what constitutes a compact vehicle. In addition, if a compact car space is available in a convenient location, many drivers of intermediate and large vehicles will attempt to utilize the space, encroaching into the adjacent space. This creates a domino effect down the row and eventually renders a parking space unusable. For these reasons, compact car only spaces are not recommended.

D. Accessibility Requirements

Accessible parking spaces must be provided according to the 2010 ADA Standards for Accessible Design (2010 Standards). In addition, certain facilities are required to provide accessible passenger loading zones. The 2010 Standards identify both the minimum dimensions and the minimum number of accessible parking spaces and loading zones required. Refer to Parts 502 and 503 of the 2010 ADA Standards for additional information.

1. **Accessible Parking Spaces:** The 2010 Standards identify two types of accessible parking spaces for vehicles - car and van-accessible parking spaces. The minimum dimensions and common requirements for each are provided below and in Figure 8B-1.02.
 - a. **Car Accessible Spaces:** Minimum width of 96 inches (8 feet 0 inches)
 - b. **Van-accessible Spaces:** Minimum width of 132 inches (11 feet 0 inches)
 - c. **Access Aisle:** An adjacent access aisle is required for both car and van-accessible spaces. Two parking spaces may share an individual access aisle.
 - 1) **Width:** The minimum width of the access aisle is 60 inches (5 feet 0 inches). If the width of the access aisle is increased to 96 inches, the width of an adjacent van-accessible parking space may be reduced from 132 inches to 96 inches. With proper layout, this allows for a reduction in the total width consumed by two adjacent van-accessible spaces.
 - 2) **Length:** The access aisle must extend the full length of the parking spaces they serve.
 - 3) **Marking:** The access aisle must be marked; however, the 2010 Standards do not indicate the type of pavement marking required. Typically, the aisle is striped at an angle. While not required, the adjacent stalls may be painted with the international symbol of accessibility (wheelchair symbol) to aid motorists in identifying the space as being reserved.
 - d. **Signage:** Accessible parking spaces must be designated with signs showing the international symbol of accessibility. Signs for van accessible spaces should also contain the designation "van accessible." Signs must be installed a minimum of 60 inches from the bottom of the sign to the ground surface. Additional signage related to enforcement or parking fines is not required by ADA.

Figure 8B-1.02: Accessible Space Dimensions

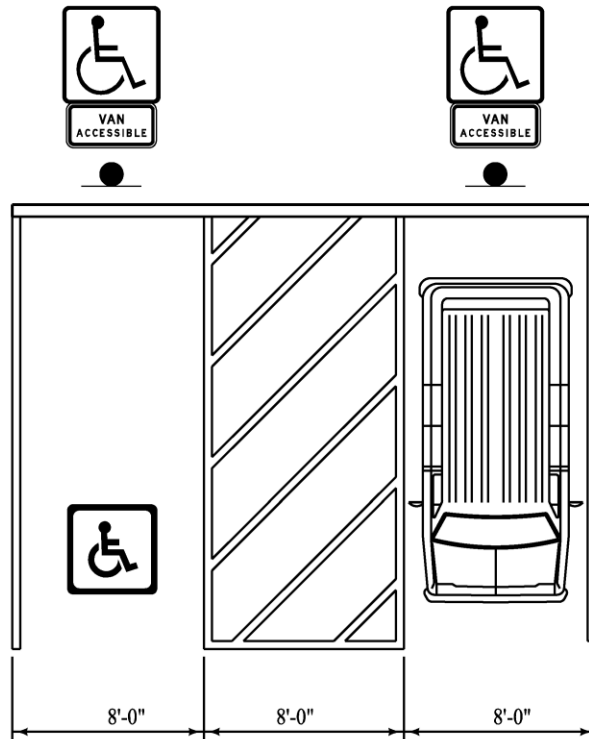
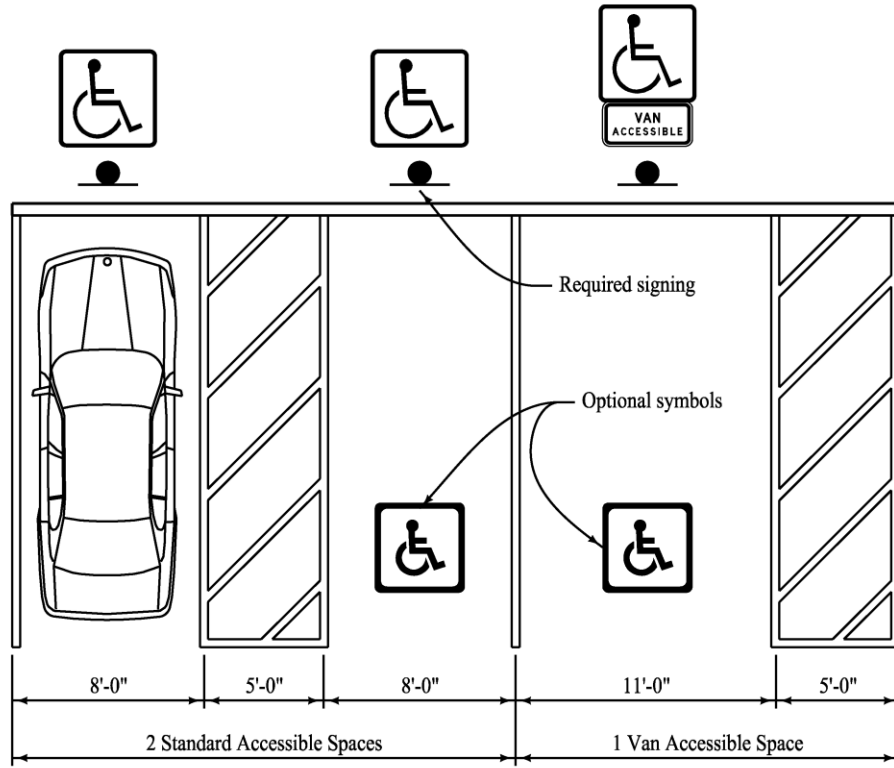

Alternate Van Accessible Parking Dimensions

2. **Passenger Loading Zone:** The 2010 ADA Standards require passenger loading zones only at licensed medical care and long-term care facilities (where the period of stay exceeds 24 hours). At other locations, the provision of passenger loading zones is optional; however, when they are provided, a portion of the loading zone must be accessible. At least one accessible passenger loading zone must be provided for every 100 continuous linear feet of loading zone space.

Passenger loading zones must have a minimum pull-up length of 20 feet and a width of 96 inches. An access aisle adjacent to the loading zone must extend the full width of the vehicle pull up space they serve and have a minimum width of 60 inches. The access aisle must be at the same elevation as the vehicle pull-up spaces that serve them. The loading zone cannot discharge to a sidewalk on top of a curb. In addition, the access aisle must be marked to discourage parking. This is typically accomplished by striping at an angle.

Figure 8B-1.03: Passenger Loading Zone Dimensions

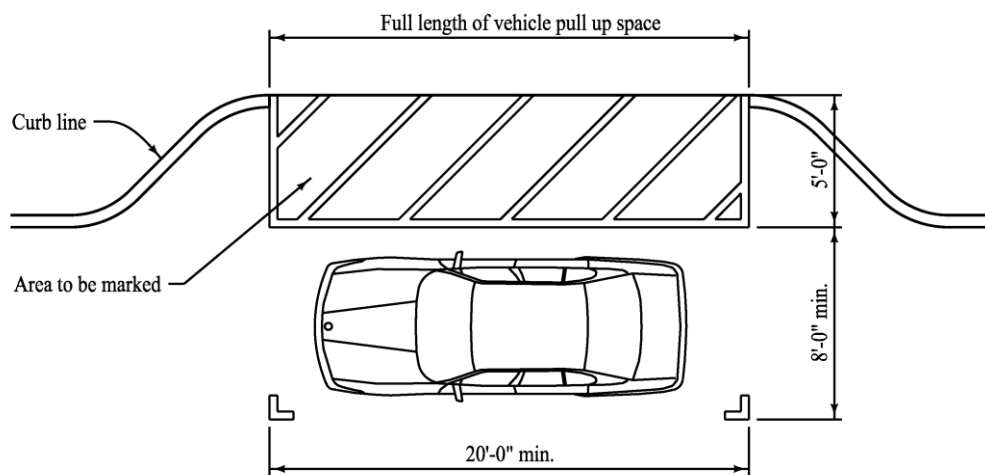

3. **Access Routes:** At least one accessible route must connect the building or destination with each accessible parking space or loading zone. To the maximum extent possible, the accessible route should coincide with the route for the general public. Like accessible off-street parking spaces and loading zones, accessible routes are covered by the 2010 ADA Standards. The basic requirements that apply to new construction for accessibility from a parking lot to a building or other destination are summarized in Chapter 4 of the 2010 Standards.
4. **On-Street Parking:** For requirements on accessibility for on-street marked or metered parking spaces, see [Section 12A-2](#).

E. Drainage

Internal parking lot drainage should be designed according to [Chapter 2 - Stormwater](#).

Stormwater runoff from parking lots serving other than single and two family dwellings should not be discharged directly into the street; such runoff should be collected internally or discharged to an adjacent drainage way. After providing detention, when required, the collected stormwater may be discharged to the public storm sewer, ditch, or other conveyance. Stormwater runoff discharged to the street over the back of the curb or through a parking lot entrance, should be minimized. Check with the local jurisdiction for their stormwater requirements.

Where narrow (less than 10 feet wide) raised islands are provided, their presence should generally be disregarded when determining the runoff coefficient or curve number for the parking lot as they provide little benefit in reducing runoff. Wider islands, or islands that are depressed to collect stormwater runoff, are encouraged and may be taken into consideration when determining the runoff potential.

Pavement slopes of 1.5% should be provided to ensure proper drainage and eliminate standing water and icy conditions. Minimum pavement slopes of 0.6% may be used, however since the potential for flat areas is greater, additional measures to address drainage, such as slotted drains or pervious pavement, may be necessary. Slopes greater than 2% in areas between the parking lot destination and the accessible parking stalls should be avoided as they create a situation where constructing an accessible route is difficult. Slopes greater than 5% are discouraged.

F. Pavement Design

Any off-street parking area should be surfaced with a flexible or rigid pavement. Check with the local jurisdiction to determine the requirements for paving parking lots. If no local requirements are stipulated, the pavement thickness for parking areas occupied by cars and small trucks for rigid and flexible pavements (see [Chapter 5 - Roadway Design](#) for mix designs) should be designed according to the following tables. It should be noted that the layer of aggregate used as the subbase needs to be drainable.

Parking lots should be designed for a minimum 20 year design life. If a design life of greater or less than 20 years is desired, see [Chapter 5 - Roadway Design](#) for pavement thickness determination. In addition, for pavements less than the recommended thickness, a pavement thickness determination should be completed to match the pavement structure with the needs of the project.

The subgrade should be designed according to [Section 6E-1](#). If soils tests are not available to determine the CBR value and uniformity of the soil (before and after construction), a CBR value of 3 and a non-uniform subgrade should be assumed.

Table 8B-1.03: Pavement Thickness for Light Loads
(Parking lots with 200 or less cars/day and/or 2 or less trucks/day or equivalent axle loads)

Subgrade CBR	Surface Material	On 12" of Prepared Subgrade		On 12" of Prepared Subgrade with 4" Granular Subbase	
		<i>Minimum</i>	<i>Desirable</i>	<i>Minimum</i>	<i>Desirable</i>
9	Rigid	5"	6"	4"	5"
	Flexible	5"	6"	4"	5"
6	Rigid	5"	6"	4"	5"
	Flexible	5"	6"	4"	5"
3	Rigid	5"	6"	4"	5"
	Flexible	6"	6"	5"	5"

Table 8B-1.04: Pavement Thickness for Moderate Loads

(Parking areas, entrances, perimeter travel lanes, and frontage roads subject to 201 to 700 cars/day and/or 3 to 50 trucks/day or equivalent axle loads)

Subgrade CBR	Surface Material	On 12" of Prepared Subgrade		On 12" of Prepared Subgrade with Granular Subbase		
		<i>Minimum</i>	<i>Desirable</i>	<i>Thickness of Granular Subbase</i>	<i>Minimum</i>	<i>Desirable</i>
9	Rigid	5"	6"	4"	4"	5"
	Flexible	5"	6"	6"	4"	5"
6	Rigid	5"	6"	6"	4.5"	5"
	Flexible	6"	6"	8"	5"	5"
3	Rigid	5.5"	6"	6"	5"	5"
	Flexible	6"	7"	8"	6"	6"

The portions of the parking facility serving truck traffic such as entrances, perimeter travel lanes, trash dumpster sites, and delivery truck routes must be designed to accommodate heavier loads. The number, type, and weight of delivery vehicles can usually be predicted with a fair level of accuracy. With this information, ESAL values and pavement thicknesses can be determined using the methodology described in [Chapter 5 - Roadway Design](#).

If the parking lot is to service an industrial area, such as a truck stop or manufacturing facility, the volume of truck traffic and the associated ESALs should be determined and an independent pavement thickness determination completed to ensure meeting the 20 year design life needs of the project.



Site Provisions

A. General

This section provides design criteria for site requirements such as number of parking spaces, landscaping, parking setback, etc. While most jurisdictions have their own parking and zoning ordinances covering these items, they are included here as guidance for those communities that do not have such ordinances. This information may also be used as a supplement to existing ordinances.

B. Number of Parking Spaces Required

- 1. General Parking Ratios:** Adequate off-street parking should be provided for all residential, commercial, industrial, and public use properties. Table 8C-1.01 below provides minimum parking space standards for common land uses. For large traffic generators, a specific parking study should be completed.

Table 8C-1.01: Parking Ratios

Land Use	Spaces per Unit
<i>Residential and Lodging</i>	
Single and two family dwellings	2.0 / unit (tandem parking allowed)
Row dwellings	2.0 / unit + 1 visitor space per 4 units
Multiple family (apartment and condo)	1 to 2 bedroom units: 2.0 spaces / unit 3+ bedroom units: 2.5 spaces per unit plus 3.0 / 1,000 sf of GFA for lease management
Mobile home park	2.0 / unit (tandem parking allowed) plus 1 visitor space per 10 units plus 3.0 / 1,000 sf of GFA for lease management
Housing for seniors	1.0 / unit plus 10 / 1,000 sf of GFA for multipurpose buildings
Hotel/motel	1.25 / room + 10 / 1,000 sf of GFA of lounge or restaurant + 20 / 1,000 sf of GFA of conference or banquet facilities
<i>Retail Sales and Services</i>	
General and convenience retail	2.75 / 1,000 sf of GFA
Grocery stores	6.75 / 1,000 sf of GFA
Heavy/hard goods	2.5 / 1,000 sf of GFA, including outdoor sales area
Discount superstores	5.5 / 1,000 sf of GFA, including outdoor sales area
Specialty superstores	4.5 / 1,000 sf of GFA, including outdoor sales area
Shopping center	Special parking study required
<i>Food and Beverage Services</i>	
Restaurant, sit down	10 / 1,000 sf of GFA
Restaurant, fast food	1.5 / 1,000 sf of GFA
Restaurant, take out only	2 / 1,000 sf of GFA
Bar/nightclub	10 / 1,000 sf of GFA
<i>Office and Business Services</i>	
< 25,000 sf of GFA	3.8 / 1,000 sf of GFA
25,000 to 100,000 sf of GFA	Scale between 3.8 and 3.4 / 1,000 sf of GFA
100,000 sf of GFA	3.4 / 1,000 sf of GFA
Consumer services	4.6 / 1,000 sf of GFA
Data processing and telemarketing	6.0 / 1,000 sf of GFA
Medical office (not part of hospital)	4.5 / 1,000 sf of GFA
<i>Industrial, Storage, and Wholesale</i>	
Manufacturing or industrial	1.85 / 1,000 sf of GFA, plus parking for office, sales, or similar use where those uses exceed 10% of sf of GFA
Storage or wholesale	0.67 / 1,000 sf of GFA
Mini-warehouse	1.75 / 1,000
<i>Educational or Institutional Uses</i>	
Elementary or middle schools	1.0 / employee + 10 spaces for visitors
High school	1.0 / employee + 0.3 / student
Church or theatre	0.4 / seat

GFA: Gross Floor Area means the area in square feet within the exterior walls of a building, exclusive of any area used for off-street parking, courtyards, or mechanical equipment.

Source: Adapted from ULI/NPA

2. **Accessible Parking Ratios:** When parking spaces are provided, a portion of the parking spaces must be made accessible according to the 2010 ADA Standards for Accessible Design (2010 Standards). These standards specify the number of parking spaces within a parking facility that must be accessible. Table 8C-1.02 summarizes the minimum accessible parking ratios. For additional information, refer to Part 208 of the 2010 Standards.

Table 8C-1.02: Minimum Accessible Parking Ratios

Total Number of Spaces Provided	Minimum Number of Accessible Spaces
1 to 25	1
26 to 50	2
51 to 75	3
76 to 100	4
101 to 150	5
151 to 200	6
201 to 300	7
301 to 400	8
401 to 500	9
501 to 1,000	2% of total
1,001 and over	20, plus 1 for each 100, or fraction thereof, over 1,000

- a. **Residential Facilities:** Accessible parking requirements for residential facilities differ from the table above and are based, in part, on the number of accessible dwelling units provided. Refer to Part 208.2.3 of the 2010 Standards for specific requirements.
- b. **Hospital Outpatient Facilities:** Ten percent of the patient and visitor parking spaces provided to serve hospital outpatient facilities shall be accessible (2010 Standards, 208.2.1).
- c. **Rehabilitation Facilities and Outpatient Physical Therapy Facilities:** Twenty percent of patient and visitor parking spaces shall be accessible. Rehabilitation and outpatient physical therapy facilities serve patients with conditions affecting mobility such as braces, canes crutches, prosthetic devices, wheelchairs or powered mobility aids, arthritis, neurological or orthopedic conditions affecting one's ability to walk, and respiratory or cardiac conditions that impose significant functional limitations (2010 Standards, 208.2.2).
- d. **Van-accessible Spaces:** For every six accessible parking spaces, or fraction thereof, one van accessible parking space must be provided. If only one accessible parking space is required, it must be van-accessible. This requirement applies to all facility types.

C. Parking Lot Setback Requirements

Tables 8C-1.03 and 8C-1.04 present recommended parking lot setback distances.

Table 8C-1.03: Residential Parking Lot Setbacks

Residential Parking Lot Location	Setback (feet)
In all residential districts (from street right-of-way)	10 ^{2, 3, 4}
Along alley line across from a residential district	5 ^{1, 2, 3}
Along adjacent residential district property lines	10 ^{2, 3}
Along adjoining residential district parking lots	5 ^{2, 3}
Along adjacent commercial or industrial district property lines	0 ^{2, 3}

¹ No setback required when use as single family, duplex, or when the use is across from a parking lot

² Setback area should consist of a permeable material and should be landscaped

³ No vehicle should encroach into a required setback

⁴ Parking on driveways parallel to a public sidewalk for single family residences should maintain a minimum setback of 10 feet from the public street right-of-way

Table 8C-1.04: Commercial / Industrial Parking Lot Setbacks

Commercial/Industrial Parking Lot Location	Setback (feet)
Along alley lines bordering a residential district	5 ^{1, 2, 3}
Commercial or industrial districts abutting a residential district	10 ^{2, 3}
Commercial or industrial districts abutting a residential district parking lot	5 ^{2, 3}
Adjacent to a commercial or industrial district property line	0 ^{2, 3}
Office and commercial districts	15 ^{2, 3, 4}
Light industrial and general industrial districts	10 ^{2, 3, 4}
Business park and professional commerce park districts	20 ^{2, 3, 4}

¹ No setback required along that portion of an alley across from a residential parking lot

² Setback area should consist of a permeable material and should be landscaped

³ No vehicle should encroach into a required setback

⁴ Setback from public street right-of-way

All parking lots should provide a curb or wheel barrier around the entire perimeter, unless a walkway or border is provided. When adjacent to required setback and adjoining property lines, wheel barriers or curbs should be located 2 feet from the edge of property lines, public sidewalks, and adjacent parking lots to prevent vehicle encroachment into the setback area.

D. Landscaping and Screening

1. General Requirements:

- a. Landscaping:** The Designer should refer to the individual Jurisdiction zoning ordinance for parking lot landscaping requirements. If no such ordinance exists then the requirements set forth in this section should be used.

It is desired that all parking areas be aesthetically improved to reduce obtrusive characteristics that are inherent to their use. Therefore, wherever practical, such parking areas should be effectively screened from general public view by incorporating the natural landscape and topography. All parking areas should include landscape areas, islands, screens, etc., equal to not less than 10% of the total paved area. Landscaped islands within the parking area should be ground cover of grass (i.e. sod), shrubs, or other acceptable living

plant life, unless an alternate ground cover is specifically approved as part of the site plan review by the Jurisdiction.

Landscape islands should not be less than a minimum of 8 feet in width from back of curb to back of curb, landscape planters a minimum 6 feet in diameter, and no parking space should be greater than 75 feet from a landscaped open space. Parking spaces should be separated from any adjoining roadway, by a landscaped island or elevated separation (i.e. sidewalk) of a minimum of 9 feet in width except along the roadway or parking bay aisle that provides the direct access.

Earthen berms should be a minimum of 3 feet above the top of curb of the adjoining parking lot, if applicable, or public thoroughfare; should be designed to not affect the drainage and sight distance of the surrounding area; and should be aesthetically pleasing to the general public. Berms may be required to be higher if the minimum height is identified during the development review process as being inadequate to provide effective screening and buffering.

- b. Screening:** Screening may consist of one or any combination of the following.
- Wood or masonry walls or fences
 - Landscaped earthen berms
 - Plant materials of such size, branching density, spacing, and quantity to provide a minimum of 60% opacity while dormant. Such materials should provide screening function within three growing seasons after the initial planting. Failure to accomplish such function, whether due to slow growth, death, or other reason, may be grounds for requiring the addition of wood or masonry walls or fences. In some Jurisdictions, a published list of approved materials may be available. Any changes to this list must be made by a certified landscape architect.

2. Additional Requirements for Parking Lots in Residential Districts:

- a. A 6 foot high opaque screen should be installed and maintained when a residential parking area abuts another lower density residential district except in any required front yard setback area. No screening is required when said residential parking area abuts another parking area or a non-residential district.
- b. A three foot high opaque screen may be installed and maintained along each alley and street line when the premises is located across the street or alley from any lower density residential district. No screening is required when said residential parking area is located across the street or alley from another parking area or from a non-residential district.

3. Additional Requirements for Parking Lots in Commercial and Industrial Districts:

- a. A 6 foot high opaque screen should be installed and maintained when a commercial and industrial parking lot abuts a residential district. No screening is required when said commercial and industrial parking area abuts another parking area or a non-residential use.
- b. A 3 foot high opaque screen should be installed and maintained along each alley and street line when the premises is located across the street or alley from any residential district. No screening is required when said commercial and industrial parking area is located across the street or alley from another parking area or from a non-residential district.
- c. A 3 foot high opaque screen should be installed and maintained along adjoining residential district. No screening is required when adjoining use is non-residential or parking.

E. Lighting

When lighting is required, cutoff style luminaries should be utilized to minimize glare and prevent light trespass onto adjacent properties. Design lighting according to [Chapter 11 - Street Lighting](#). Check with the local jurisdiction for lighting requirements. If none exist, refer to Table 8C-1.05 for the recommended illuminance values and uniformity ratios for parking lots.

Table 8C-1.05: Recommended Maintained Illuminance Values and Uniformity Ratios

	Basic	Enhanced Security
Minimum horizontal illuminance on surface	0.2 footcandles	0.5 footcandles
Minimum vertical illuminance at 5 feet above surface	0.1 footcandles	0.25 footcandles
Uniformity ratio (max. to min.)	20:1	15:1

Source: ULI / NPA

F. Pavement Markings

The location of each parking space and direction of traffic flow should be identified by surface markings and should be maintained so as to be readily visible at all times. In general, yellow markings tend to stand out better than white from the background parking surface. White paint on concrete also tends to fade with time, making it difficult to distinguish the striping. All pavement striping should be 4 inches in width. Markings may either be painted or cold applied marking tape.