

SUDAS Revision Submittal Form

Status Date: As of 10/21/2021 **Topic:** Driveway curb transition
Manual: Specifications **Manual Location:** Figures 7030.101 and 7030.102

Requested Revision: See attached figures.

Reason for Revision: Added information on the slope of the curb transition at driveways.

Comments: None.

District: 1 2 3 4 5 6 **October 2021 Webinars**

District 6 - concerned about getting exactly a 1:1 slope; suggested adding "nominal" to the 1:1 wording.

Comments: District 5 - agreed with District 6 but also suggested adding "minimum" to the 1:1 wording.

Note - added the word "minimum" to cover both districts' concerns.

Action: Deferred Not Approved Approved

Final District Action Summary: All districts approved.

Board of Directors Action:

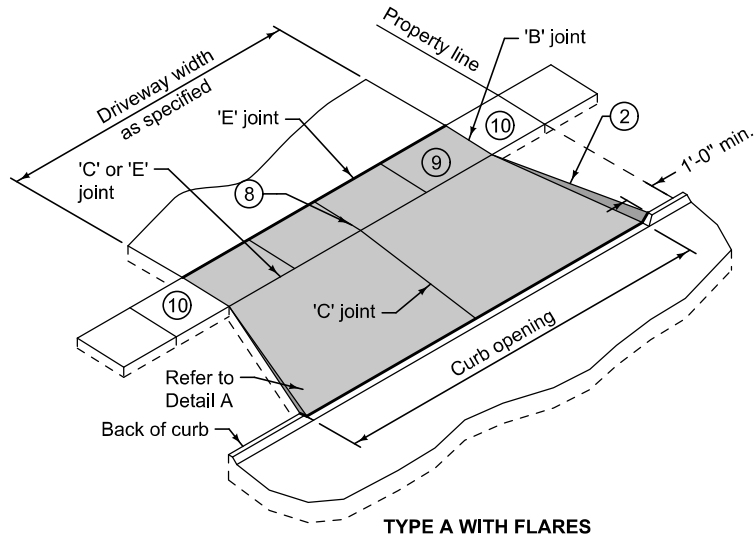

TYPE A WITH FLARES

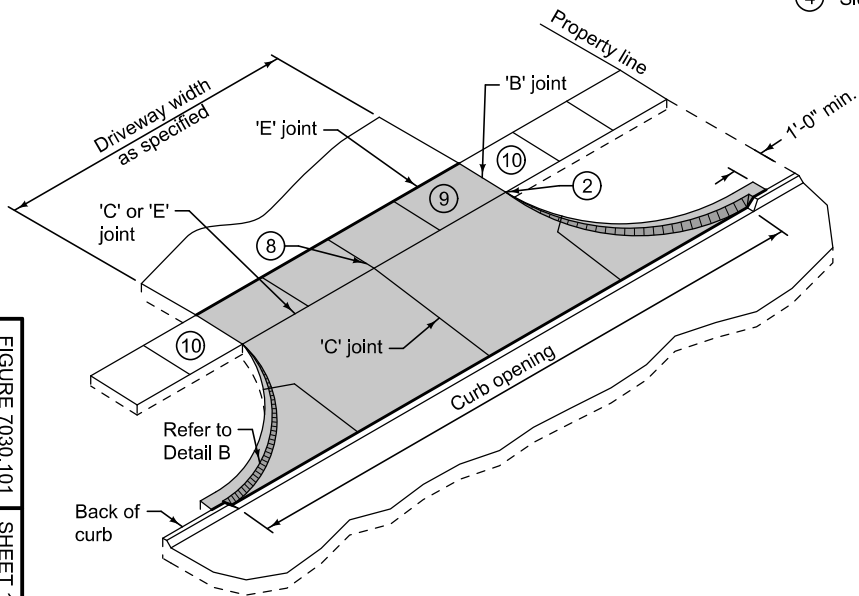

TYPE A WITH RADII

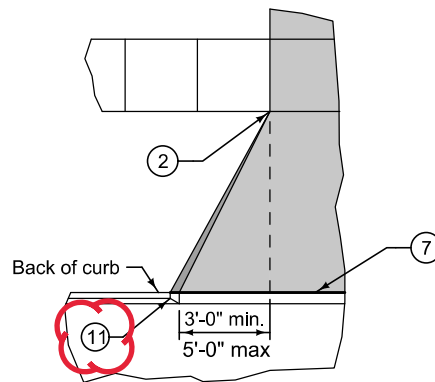

DETAIL A
(Residential/Agricultural Only)

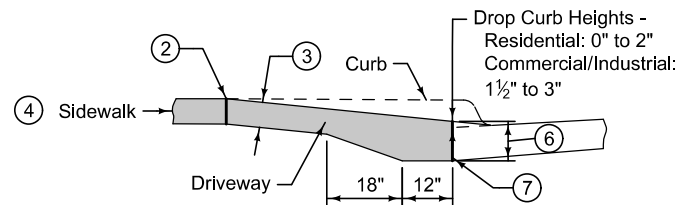

TYPICAL SECTION

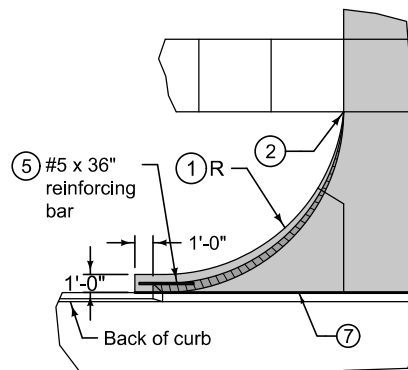

DETAIL B

- ① Driveway radius (R).
Residential: 10 foot minimum, 15 foot maximum.
Commercial and industrial: As specified in the contract documents.
- ② Transition the curb height to 0 inches at end of taper/radius or at the front edge of sidewalk. Do not extend raised curb across sidewalk.
- ③ Pavement thickness.
Residential: 6 inches minimum.
Commercial and industrial: 7 inches minimum.
- ④ Sidewalk thickness through driveway to match thickness of driveway.
- ⑤ Center reinforcing bar vertically in the pavement.
- ⑥ Match thickness of adjacent roadway, 8 inches minimum.
- ⑦ Provide 'E' joint at back of curb unless 'B' joint is specified.
- ⑧ For alleys, invert the pavement crown 2% toward center of alley.
- ⑨ Target cross slope of 1.5% with a maximum cross slope of 2.0%. If specified in the contract documents, construct the sidewalk through the driveway 5 feet wide to serve as a passing space.
- ⑩ If cross slope of adjacent sidewalk panel exceeds 2.0%, remove and replace to transition from existing sidewalk to sidewalk through driveway. If elevation change requires a curb ramp, comply with Figure 7030.205; verify need for detectable warning panel with Engineer.
- ⑪ Transition street curb at minimum 1:1 slope to meet driveway curb.

	REVISION 4 2022 Edition
	7030.101 SHEET 1 of 1
SUDAS Standard Specifications	
CONCRETE DRIVEWAY, TYPE A	

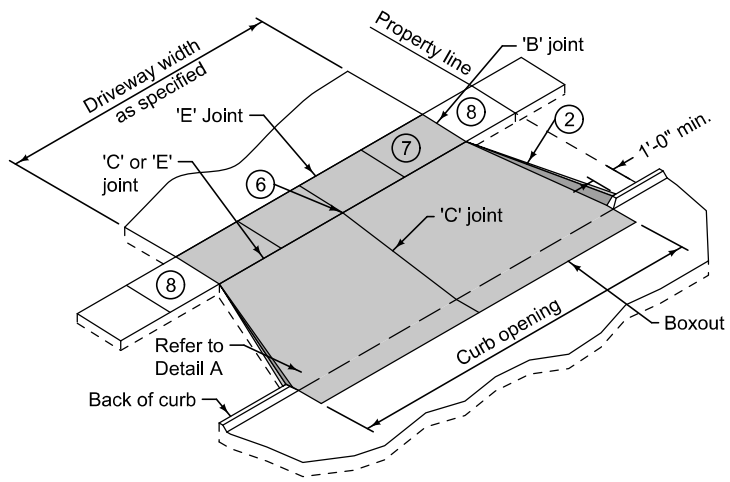

TYPE B WITH FLARES

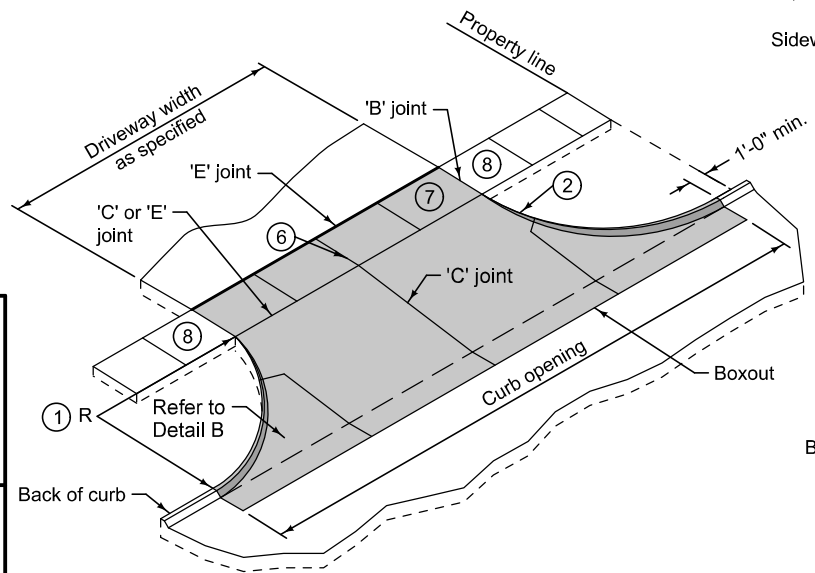

TYPE B WITH RADII

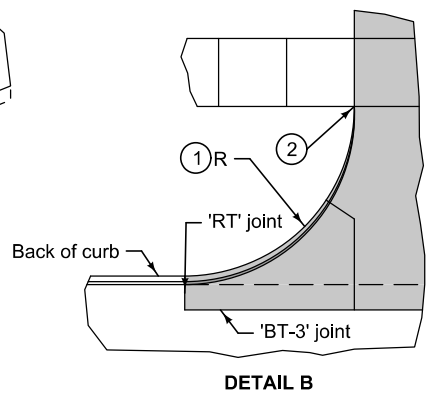
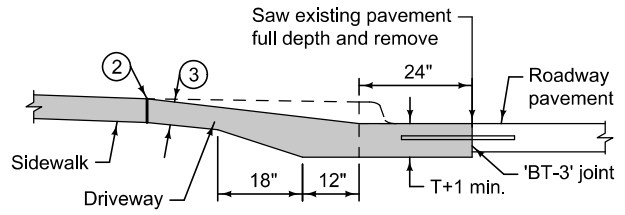
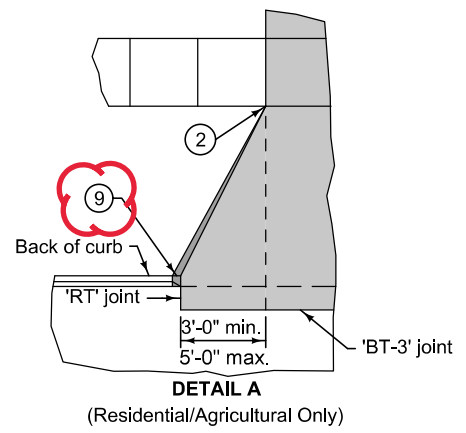

- ① Driveway radius (R).
Residential: 10 foot minimum, 15 foot maximum.
Commercial and industrial: As specified in the contract documents.
- ② Transition the curb height to 0 inches at end of taper/radius or at the front edge of sidewalk. Do not extend raised curb cross sidewalk.
- ③ Pavement thickness.
Residential: 6 inches minimum.
Commercial and industrial: 7 inches minimum.
- ④ Sidewalk thickness through driveway to match thickness of driveway.
- ⑤ If longitudinal joint is located 48 inches or less from the back of curb, extend boxout to joint line. Full depth saw cut is still required.
- ⑥ For alleys, invert the pavement crown 2% toward the center of the alley.
- ⑦ Target cross slope of 1.5% with a maximum cross slope of 2.0%. If specified in the contract documents, construct the sidewalk through the driveway 5 feet wide to serve as a passing space.
- ⑧ If cross slope of adjacent sidewalk panel exceeds 2.0%, remove and replace to transition from existing sidewalk to sidewalk through driveway. If the elevation change requires a curb ramp, comply with Figure 7030.205; verify need for detectable warning panel with Engineer.
- ⑨ Transition street curb at minimum 1:1 slope to meet driveway curb.

FIGURE 7030.102 SHEET 1 OF 1

	REVISION 4 2022 Edition
	SUDAS 7030.102 SHEET 1 of 1
SUDAS Standard Specifications	
CONCRETE DRIVEWAY, TYPE B	