

**Table of Contents**

<b>Section 5010 - Pipe and Fittings</b>	<b>Page No.</b>
<b>Part 1 - General</b>	
1.01 Section Includes	1
1.02 Description of Work	1
1.03 Submittals	1
1.04 Substitutions	1
1.05 Delivery, Storage, and Handling	1
1.06 Scheduling and Conflicts	1
1.07 Special Requirements	1
1.08 Measurement and Payment	1
<b>Part 2 - Products</b>	
2.01 Water Main	5
2.02 Bolts for Water Main and Fittings	6
2.03 Fittings	6
2.04 Concrete Thrust Blocks	7
2.05 Pipeline Accessories	6
2.06 Special Gaskets	8
2.07 Water Service Pipe and Appurtenances	8
2.08 Non-shrink Grout	8
2.09 Casing Pipe	8
<b>Part 3 - Execution</b>	
3.01 Pipe Installation	9
3.02 Additional Requirements for DIP Installation	9
3.03 Additional Requirements for PVC Pipe Installation	10
3.04 Polyethylene Encasement Installation	10
3.05 Tracer System Installation	10
3.06 Conflicts	11
3.07 Transitions in Piping Systems	12

<b>Section 5010 - Pipe and Fittings (Continued)</b>		<b>Page No.</b>
3.08	Structure Penetrations	12
3.09	Water Service Stub	12
3.10	Water Main Abandonment	12
3.11	Water Main Removal	13
3.12	Testing and Disinfection	13
<b>Figures</b>		<b>Figure No.</b>
	Thrust Blocks	5010.101
	Tracer System	5010.102
	Minimum Clearance Between Water Service and Structure	5010.901
<b>Section 5011 - Fusible PVC and HDPE Pipe</b>		<b>Page No.</b>
<b>Part 1 - General</b>		
1.01	Section Includes	1
1.02	Description of Work	1
1.03	Submittals	1
1.04	Substitutions	1
1.05	Delivery, Storage, and Handling	1
1.06	Scheduling and Conflicts	2
1.07	Special Requirements	2
1.08	Measurement and Payment	2
<b>Part 2 - Products</b>		
2.01	Water Main	4
<b>Part 3 - Execution</b>		
3.01	Additional Requirements for Fusible Pipe Installation	5
3.02	Testing and Disinfection	6
<b>Section 5020 - Valves, Fire Hydrants, and Appurtenances</b>		
<b>Part 1 - General</b>		
1.01	Section Includes	1
1.02	Description of Work	1

<b>Section 5020 - Valves, Fire Hydrants, and Appurtenances (Continued)</b>		<b>Page No.</b>
1.03	Submittals	1
1.04	Substitutions	1
1.05	Delivery, Storage, and Handling	1
1.06	Scheduling and Conflicts	1
1.07	Special Requirements	1
1.08	Measurement and Payment	1
<b>Part 2 - Products</b>		
2.01	Valves	4
2.02	Fire Hydrant Assembly	5
2.03	Appurtenances	6
<b>Part 3 - Execution</b>		
3.01	General	7
3.02	Flushing Device (Blowoff)	7
3.03	Fire Hydrant	7
3.04	Adjustment of Existing Valve Box or Fire Hydrant	7
<b>Figures</b>		<b>Figure No.</b>
	Fire Hydrant Assembly	5020.201
<b>Section 5030 - Testing and Disinfection</b>		<b>Page No.</b>
<b>Part 1 - General</b>		
1.01	Section Includes	1
1.02	Description of Work	1
1.03	Submittals	1
1.04	Substitutions	1
1.05	Delivery, Storage, and Handling	1
1.06	Scheduling and Conflicts	1
1.07	Special Requirements	1
1.08	Measurement and Payment	1
<b>Part 2 - Products</b>		
2.01	Disinfection Agent - Chlorine	2

**Section 5030 - Testing and Disinfection (Continued)****Page No.****Part 3 - Execution**

3.01	General	3
3.02	Sequence of Testing and Disinfection	3
3.03	Initial Flushing	3
3.04	Pressure and Leak Testing	4
3.05	Disinfection	5
3.06	Final Flushing	5
3.07	Bacteria Sampling	6
3.08	Re-disinfection	6
3.09	Putting Water Main in Service	6

---

**PIPE AND FITTINGS****PART 1 - GENERAL****1.01 SECTION INCLUDES**

- A. Pipe
- B. Fittings
- C. Special Fittings
- D. Pipeline Accessories

**1.02 DESCRIPTION OF WORK**

Construct water mains and building service pipes.

**1.03 SUBMITTALS**

Comply with Division 1 - General Provisions and Covenants, as well as the following:

Submit product information sheet for joint restraint system to be used.

**1.04 SUBSTITUTIONS**

Comply with Division 1 - General Provisions and Covenants.

**1.05 DELIVERY, STORAGE, AND HANDLING**

Comply with Division 1 - General Provisions and Covenants, as well as the following:

Remove pipe and fittings contaminated with mud and surface water from the site; do not use in construction unless thoroughly cleaned, inspected, and approved by the Engineer.

**1.06 SCHEDULING AND CONFLICTS**

Comply with Division 1 - General Provisions and Covenants.

**1.07 SPECIAL REQUIREMENTS**

None.

**1.08 MEASUREMENT AND PAYMENT****A. Water Main:****1. Trenched:**

- a. **Measurement:** Each type and size of pipe installed in an open trench will be measured in linear feet along the centerline of the pipe, including the length through the fittings.
- b. **Payment:** Payment will be made at the unit price per linear foot for each type and size of pipe.
- c. **Includes:** Unit price includes, but is not limited to, trench excavation; dewatering; furnishing and installing pipe; furnishing, placing, and compacting bedding and backfill material; tracer system; testing; disinfection; and polyethylene wrap for ductile iron pipe and for fittings.

**1.08 MEASUREMENT AND PAYMENT (Continued)****2. Trenchless:**

- a. Measurement:** Each type and size of pipe installed by trenchless methods will be measured in linear feet along the centerline of the pipe.
- b. Payment:** Payment will be made at the unit price per linear foot for each type and size of pipe.
- c. Includes:** Unit price includes, but is not limited to, furnishing and installing pipe; trenchless installation materials and equipment; pit excavation; dewatering; placing and compacting backfill material; tracer system; testing; and disinfection.

**B. Water Main with Casing Pipe:****1. Trenched:**

- a. Measurement:** Each type and size of pipe with a casing pipe installed in an open trench, will be measured in linear feet along the centerline of the casing pipe from end of casing to end of casing.
- b. Payment:** Payment will be made at the unit price per linear foot for each type and size of carrier pipe.
- c. Includes:** Unit price includes, but is not limited to, furnishing and installing both carrier pipe and casing pipe; trench excavation; dewatering; furnishing and installing pipe; furnishing, placing, and compacting bedding and backfill material; casing spacers; furnishing and installing annular space fill material; tracer system; testing; and disinfection.

**2. Trenchless:**

- a. Measurement:** Each type and size of pipe installed by trenchless methods with a casing pipe will be measured in linear feet along the centerline of the casing pipe.
- b. Payment:** Payment will be made at the unit price per linear foot for each type and size of carrier pipe.
- c. Includes:** Unit price includes, but is not limited to, furnishing and installing both carrier pipe and casing pipe; trenchless installation materials and equipment; pit excavation; dewatering; placing and compacting backfill material; casing spacers; furnishing and installing annular space fill material; tracer system; testing; and disinfection.

**C. Fittings:** One of the following methods will be specified for measurement and payment of water main fittings.**1. Fittings by Count:**

- a. Measurement:** Each type and size of fitting installed as specified in the contract documents or as required for proper installation of the water main will be counted.
- b. Payment:** Payment will be made at the unit price for each type and size of fitting.
- c. Includes:** Unit price includes, but is not limited to, restrained joints and thrust blocks.

**2. Fittings by Weight:**

- a. Measurement:** Each type and size of fitting installed as specified in the contract documents or as required for proper installation of the water main will be counted. Determine the total weight of fittings counted, in pounds, based on the standard fitting weights published in AWWA C153 for ductile iron compact fittings.
- b. Payment:** Payment will be made at the unit price per pound for each type and size of fitting.
- c. Includes:** Unit price includes, but is not limited to, restrained joints and thrust blocks.

**1.08 MEASUREMENT AND PAYMENT (Continued)****D. Water Service Stubs by Each:**

1. **Measurement:** Each type and size of water service stub from the water main to the stop box will be counted.
2. **Payment:** Payment will be made at the unit price for each type and size of water service stub.
3. **Includes:** Unit price includes, but is not limited to, water service corporation; service pipe; curb stop; stop box; trench excavation; dewatering; furnishing and installing pipe; furnishing, placing, and compacting bedding and backfill material; and installation of tracer wire system for non-metallic service pipe.

**E. Water Service Stubs by Length:**

1. **Water Service Pipe:**
  - a. **Measurement:** Each type and size of water service pipe will be measured in linear feet along the centerline of the pipe.
  - b. **Payment:** Payment will be made at the unit price per linear foot of each type and size of water service pipe.
  - c. **Includes:** Unit price includes, but is not limited to, trench excavation; dewatering; furnishing and installing pipe; furnishing, placing, and compacting bedding and backfill material; and installation of tracer wire system for non-metallic service pipe.
2. **Water Service Corporation:**
  - a. **Measurement:** Each type and size of water service corporation will be counted.
  - b. **Payment:** Payment will be made at the unit price for each type and size of water service corporation.
3. **Water Service Curb Stop and Box:**
  - a. **Measurement:** Each type and size of water service curb stop and box will be counted.
  - b. **Payment:** Payment will be made at the unit price for each type and size of water service curb stop and box.

**F. Water Main Abandonment, Cap:**

1. **Measurement:** Each size and location of water main to be abandoned will be counted.
2. **Payment:** Payment will be made at the unit price for each size and location of water main abandoned.
3. **Includes:** Unit price includes, but is not limited to, trench excavation (if necessary); closing valves; removing valve boxes; installing thrust blocks; cutting pipe; installing MJ caps; and furnishing, placing, and compacting backfill material.

**1.08 MEASUREMENT AND PAYMENT (Continued)****G. Water Main Abandonment, Fill and Plug:**

1. **Measurement:** Each size and location of water main to be abandoned by filling and plugging will be measured in linear feet.
2. **Payment:** Payment will be made at the unit price per linear foot of water main filled and plugged.
3. **Includes:** Unit price includes, but is not limited to, trench excavation (if necessary); closing valves; removing valve boxes; installing thrust blocks; cutting and removing the specified section of pipe; furnishing and pumping flowable material to fill the pipe to be abandoned; installing MJ caps; and furnishing, placing, and compacting backfill material.

**H. Water Main Removal:**

1. **Measurement:** Each size and location of water main to be removed will be measured in linear feet from end to end.
2. **Payment:** Payment will be made at the unit price per linear foot for each pipe removed.
3. **Includes:** Unit price includes, but is not limited to, trench excavation (if necessary); closing valves; installing thrust blocks; cutting pipe; installing MJ caps; removal and disposal of all valves and pipe specified for removal; furnishing, placing, and compacting backfill material.



---

**PART 2 - PRODUCTS****2.01 WATER MAIN**

- A. Polyvinyl Chloride (PVC) Pipe:** Comply with AWWA C900 with ductile iron pipe equivalent outside diameters.
- 1. Minimum Wall Thickness:**
    - a. 4 inch through 24 inch sizes:** DR 18.
    - b. Sizes over 24 inch:** As specified in the contract documents.
  - 2. Joint Type:** Use push-on joint type, except as otherwise specified in the contract documents or as authorized by the Engineer.
    - a. Push-on:** According to AWWA C900.
    - b. Integral Restrained Joint:** AWWA C900 pipe with restraining system manufactured integrally into pipe end.
    - c. Mechanical Restrained Joint:** Ductile iron mechanical device designed for joint restraint of AWWA C900 pipe complying with the requirements of ASTM F 1674.
  - 3. Markings on Pipe:**
    - a. Name of manufacturer.
    - b. Size and class.
    - c. Spigot insertion depth gauge.
    - d. National Sanitation Foundation (NSF) seal.
- B. Ductile Iron Pipe (DIP):**
- 1. Minimum Thickness Class:**
    - a. 4 inch through 24 inch sizes:** Special thickness Class 52 according to AWWA C151.
    - b. Sizes over 24 inches:** As specified in the contract documents.
  - 2. Cement-mortar Lined:** According to AWWA C104 with seal coat.
  - 3. External Coating:** Seal coat according to AWWA C151.
  - 4. Joint Type:** Use push-on type, unless otherwise specified in the contract documents or as authorized by the Engineer.
    - a. Push-on:** According to AWWA C111.
    - b. Mechanical:** According to AWWA C111.
    - c. Restrained, Buried:** Pipe manufacturer's standard field removable system.
    - d. Restrained, in Structures:** Restraining gland, flanged or grooved/shouldered.
    - e. Flanged:** According to AWWA C111.
    - f. Grooved/Shouldered:** According to AWWA C606.
    - g. Gaskets:** According to AWWA C111.
  - 5. Markings on Pipe:**
    - a. Name of manufacturer.
    - b. Size and class.
    - c. Spigot insertion depth gauge.

**2.02 BOLTS FOR WATER MAIN AND FITTINGS**

Use corrosion resistant bolts.

**A. Tee-bolts and Hexagonal Nuts for Mechanical Joints:**

1. High-strength, low-alloy steel manufactured according to AWWA C111.
2. Provide ceramic-filled, baked-on, fluorocarbon resin coating for bolts and nuts.
3. Include factory-applied lubricant that produces low coefficient of friction for ease of installation.

**B. Other Bolts and Nuts:**

1. Stainless steel.
2. Ductile iron.
3. Zinc, zinc chromate, or cadmium plated.

**2.03 FITTINGS****A. For DIP and PVC Pipe:** Comply with AWWA C110 (ductile iron or gray iron) or AWWA C153 (ductile iron).**1. Joint Type:**

- a. For pipe sizes 16 inches and less, use mechanical joint complying with AWWA C111.
  - b. For pipe sizes greater than 16 inches, use restrained mechanical joint system. Provide follower gland using breakaway torque bolts to engage thrust restraint.
    - 1) Minimum pressure rating same as connecting pipe. For fittings between dissimilar pipes, the minimum pressure rating is the lesser of the two pipes.
    - 2) Suitable for buried service.
    - 3) Joint restraint system to be field installable, field removable, and re-installable.
  - c. Use of alternate restraint systems must be approved by the Engineer.
2. **Lined:** Cement mortar lined according to AWWA C104 with seal coat or protective fusion bonded coatings per AWWA C116.
  3. **Wall Thickness:** Comply with AWWA C153.
  4. **Gaskets:** Comply with AWWA C111.

**B. Flange Adapter:**

1. **Body:** Ductile iron complying with ASTM A 536.
2. **End Rings (Follower Rings):** Ductile iron complying with ASTM A 536.
3. **Gaskets:** New rubber compounded for water service and resistant to permanent set.
4. **Bolts and Nuts:** High strength, low alloy corrosion resistant steel or carbon steel bolts complying with ASTM A 307.

**2.03 FITTINGS (Continued)****C. Pipe Coupling:**

1. **Center Sleeve (Center Ring):** Steel pipe or tubing complying with ASTM A 53 or ASTM A 512, or formed carbon steel with a minimum yield of 30,000 psi.
2. **End Ring (Follower Ring):** Ductile iron complying with ASTM A 536, or steel meeting or exceeding the requirements of ASTM A 576, grade 1010-1020.
3. **Gaskets:** New rubber compounded for water service and resistant to permanent set.
4. **Bolts and Nuts:** High strength, low alloy corrosion resistant steel.

**2.04 CONCRETE THRUST BLOCKS**

- A. Use Iowa DOT Class C concrete.
- B. Comply with the contract documents for dimensions and installation of thrust blocks. Comply with [Figure 5010.101](#).
- C. Use for all pipe sizes 16 inches in diameter or smaller or when specified.

**2.05 PIPELINE ACCESSORIES****A. Polyethylene Wrap:**

1. Comply with AWWA C105.
2. Provide tubes or sheets with 8 mil minimum thickness.

**B. Tracer System:** Comply with [Figure 5010.102](#).**1. Tracer Wire:****a. Open Cut:****1) Solid Single Copper Conductor:**

- a) **Size:** #12 AWG
- b) **Insulation Material:** Linear low-density polyethylene (LLDPE) insulation suitable for direct burial applications
- c) **Insulation Thickness:** 0.030 inches, minimum
- d) **Tensile Strength:** 150 pounds, minimum
- e) **Operating Voltage:** Rated for 30 volts

**2) Bimetallic Copper Clad Steel Conductor:**

- a) **Size:** #14 AWG
- b) **Rating:** Direct burial
- c) **Operating Voltage:** Rated for 30 volts
- d) **Conductivity:** 21%
- e) **Copper Cladding:** 3% of conductor diameter, minimum
- f) **Insulation Material:** High density, high molecular weight polyethylene
- g) **Insulation Thickness:** 0.030 inches, minimum
- h) **Tensile Strength:** 175 pounds, minimum

**b. Directional Drilling/Boring:****1) Bimetallic Copper Clad Steel Conductor:**

- a) **Size:** #12 AWG
- b) **Rating:** Direct burial
- c) **Operating Voltage:** Rated for 30 volts
- d) **Conductivity:** 21%

**2.05 PIPELINE ACCESSORIES (Continued)**

- e) **Copper Cladding:** 3% of conductor diameter, minimum
  - f) **Insulation Material:** High density, high molecular weight polyethylene
  - g) **Insulation Thickness:** 0.045 inches, minimum
  - h) **Tensile Strength:** 1,100 pounds, minimum
2. **Ground Rod:** 3/8 inch diameter, 60 inch steel rod uniformly coated with metallicly bonded electrolytic copper.
  3. **Ground-rod Clamp:** High-strength, corrosion-resistant copper alloy.
  4. **Splice Kit:** Inline resin splice kit with split bolt (1 kV and 5 kV) for use with single conductor and unshielded cable splices in direct bury and submersible applications.
  5. **Tracer Wire Station:** Comply with the contract documents.

**2.06 SPECIAL GASKETS**

- A. For soils contaminated with gasoline, use neoprene or nitrile gaskets.
- B. For soils contaminated with volatile organic compounds, use nitrile or fluorocarbon gaskets.
- C. For other soil contaminants, contact the Engineer for the required gasket.

**2.07 WATER SERVICE PIPE AND APPURTENANCES**

- A. **Controlling Standards:** Local plumbing and fire codes.
- B. **Materials** (as allowed by Jurisdiction or specified in contract documents):
  1. **Copper Pipe:**
    - a. Comply with ASTM B 88.
    - b. Wall Thickness: Type K.
  2. **DIP:** As specified in Section 5010, 2.01. Polyethylene wrap is required.
  3. **PVC Pipe:** ASTM D 1785, Schedule 80 or ASTM D 2241, SDR 21. Provide solvent weld joints for all pipes.
  4. **Brass Pipe:** Red, seamless, according to ASTM B 43.
  5. **Polyethylene Pipe:** Class 200, according to AWWA C901.
- C. **Corporations, Stops, and Stop Boxes:** Contact the Jurisdiction for requirements.

**2.08 NON-SHRINK GROUT**

Comply with [Iowa DOT Materials I.M. 491.13](#).

**2.09 CASING PIPE**

Comply with [Section 3020](#).

**PART 3 - EXECUTION****3.01 PIPE INSTALLATION****A. General:**

1. Do not use deformed, defective, gouged, or otherwise damaged pipes or fittings.
2. Keep trench free of water. Clean pipe interior prior to placement in the trench.
3. Install pipe with fittings and valves to the lines and grades specified in the contract documents.
4. Clean joint surfaces thoroughly and apply lubricant approved for use with potable water and recommended by the manufacturer.
5. Push pipe joint to the indication line on the spigot end of the pipe before making any joint deflections.
6. Limit joint deflections to one degree less than pipe manufacturer's recommended maximum limit.
7. Tighten bolts in a joint evenly around the pipe.
8. Install concrete thrust blocks on all fittings 16 inches in diameter or smaller (comply with [Figure 5010.101](#)). For fittings larger than 16 inches, install restrained joints, and when specified in the contract documents, also install concrete thrust blocks.
9. Keep exposed pipe ends closed with rodent-proof end gates at all times when pipe installation is not occurring.
10. Close the ends of the installed pipe with watertight plugs during nights and non-working days.
11. Do not allow any water from the new pipeline to enter the existing distribution system piping until testing and disinfection are successfully completed.

**B. Trenched:**

1. Excavate trench and place pipe bedding and backfill material as specified in [Section 3010](#).
2. Provide uniform bearing along the full length of the pipe barrel. Provide bell holes.

**C. Trenchless:** Comply with [Section 3020](#).**3.02 ADDITIONAL REQUIREMENTS FOR DIP INSTALLATION**

- A. Utilize full-length gauged pipe for field cuts. Alternatively, use a MJ gland or other approved method to field-gauge pipe selected for cutting to verify the outside diameter is within allowable tolerances.
- B. Cut the pipe perpendicular to the pipe barrel. Do not damage the cement lining. Bevel cut, file, or grind the ends for push-on joints according to the manufacturer's recommendations.
- C. Encase all pipe, valves, and fittings with polyethylene wrap according to Section 5010, 3.05.
- D. Install pipe according to AWWA C600, except as modified herein.

**3.03 ADDITIONAL REQUIREMENTS FOR PVC PIPE INSTALLATION**

- A. Cut the pipe perpendicular to the pipe barrel. Deburr and bevel cut spigot end of the pipe barrel to match factory bevel. Re-mark the insertion line.
- B. When connecting to shallow-depth bells, such as on some cast iron fittings or valves, cut the spigot end square to remove factory bevel. Deburr the end and form a partial bevel on the end.
- C. Install pipe according to AWWA C605, except as modified herein.

**3.04 POLYETHYLENE ENCASUREMENT INSTALLATION**

- A. Apply polyethylene encasement to buried ductile iron pipe and to buried fittings, fire hydrants, and appurtenances. The polyethylene encasement is used to prevent contact between the pipe and the bedding material, but need not be airtight or watertight.
- B. Install polyethylene encasement according to AWWA C105, using tubes or flat sheets, and pipe manufacturer's recommendations.
- C. Do not expose the polyethylene encasement to sunlight for long periods before installation.
- D. Remove all lumps of clay, mud, cinders, etc. on the pipe surface before encasing the pipe. Take care to prevent soil or bedding material from becoming trapped between the pipe and polyethylene.
- E. Lift polyethylene-encased pipe with a fabric-type sling or padded cable.
- F. Secure and repair encasement material using polyethylene tape, or replace as necessary.

**3.05 TRACER SYSTEM INSTALLATION**

- A. Install with all buried water main piping. Comply with [Figure 5010.102](#) for tracer wire installation.
- B. Begin and terminate the system at all connections to existing mains.
- C. Install wire continuously along the lower quadrant of the pipe. Do not install wire along the bottom of the pipe. Attach wire to the pipe at the midpoint of each pipe length; use 2 inch wide, 10 mil thickness polyethylene pressure sensitive tape.
- D. Install splices only as authorized by the Engineer. Allow the Engineer to inspect all below-grade splices of tracer wire prior to placing the backfill material.
- E. Install ground rods adjacent to connections to existing piping and at locations specified in the contract documents or as directed by the Engineer.
- F. Bring two wires to the surface at each fire hydrant location and terminate with a tracer wire station (comply with [Figure 5010.102](#)).
- G. Final inspection of the tracer system will be conducted at the completion of the project and prior to acceptance by the owner. Verify the electrical continuity of the system. Repair discontinuities.

**3.06 CONFLICTS****A. Horizontal Separation of Gravity Sewers from Water Mains:**

1. Separate gravity sewer mains from water mains by a horizontal distance of at least 10 feet unless:
  - The top of a sewer main is at least 18 inches below the bottom of the water main, and
  - The sewer is placed in a separate trench or in the same trench on a bench of undisturbed earth at a minimum horizontal separation of 3 feet from the water main.
2. When it is impossible to obtain the required horizontal clearance of 3 feet and a vertical clearance of 18 inches between sewers and water mains, the sewers must be constructed of water main materials meeting the requirements of Section 5010, 2.01. However, provide a linear separation of at least 2 feet.

**B. Separation of Sewer Force Mains from Water Mains:** Separate sewer force mains and water mains by a horizontal distance of at least 10 feet unless:

1. The force main is constructed of water main materials meeting a minimum pressure rating of 150 psi and the requirements of Section 5010, 2.01 and
2. The sewer force main is laid at least 4 linear feet from the water main.

**C. Separation of Sewer and Water Main Crossovers:**

1. Vertical separation of sanitary and storm sewers crossing under any water main should be at least 18 inches when measured from the top of the sewer to the bottom of the water main. If physical conditions prohibit the separation, the sewer may be placed not closer than 6 inches below a water main or 18 inches above a water main. Maintain the maximum feasible separation distance in all cases. The sewer and water pipes must be adequately supported and have watertight joints. Use a low permeability soil for backfill material within 10 feet of the point of crossing.
2. Where the sanitary sewer crosses over or less than 18 inches below a water main, locate one full length of sewer pipe of water main material so both joints are as far as possible from the water main.
3. Where the storm sewer crosses over or less than 18 inches below a water main, locate one full length of sewer pipe of water main material or reinforced concrete pipe (RCP) with flexible gasket joints meeting ASTM C 443 so both joints are as far as possible from the water main.

**D. Surface Water Crossings:** Comply with the Recommended Standards for Water Works, 2007 Edition.

1. **Above-water Crossings:** Ensure the pipe is adequately supported and anchored; protected from vandalism, damage, and freezing; and accessible for repair or replacement.
2. **Underwater Crossings:** Provide a minimum cover of 5 feet over the pipe unless otherwise specified in the contract documents. When crossing water courses that are greater than 15 feet in width, provide the following.
  - a. pipe with flexible, restrained, or welded watertight joints,
  - b. valves at both ends of water crossings so the section can be isolated for testing or repair; ensure the valves are easily accessible and not subject to flooding, and
  - c. permanent taps or other provisions to allow insertion of a small meter to determine leakage and obtain water samples on each side of the valve closest to the supply source.

**3.07 TRANSITIONS IN PIPING SYSTEMS**

Where the specified material of a piping system entering or exiting a structure changes, make the change at the outside of the structure wall, beyond any wall pipe or wall fitting required, unless otherwise specified.

**3.08 STRUCTURE PENETRATIONS****A. Wall Pipes:**

1. Install where pipes penetrate and terminate at a wall or floor surface of a concrete structure, or where the pipe protrudes through the concrete wall or floor and the protrusion is otherwise unsupported.
2. Provide a waterstop flange near the center of the embedment length. The waterstop is to be cast integrally with the wall pipe, or fully welded to it around the pipe circumference.

**B. Wall Sleeves:**

1. Install where a pipe passes through a structure wall.
2. Sleeves in concrete walls are to be supplied with a waterstop collar, fully welded, and cast-in-place in the concrete.

**3.09 WATER SERVICE STUB**

- A. Install water service pipe, corporations, stops, and stop boxes according to local Jurisdiction requirements.
- B. Install 1 inch and smaller corporation valves tapped at 45 degrees above horizontal at a minimum distance of 18 inches from pipe bell or other corporation. Install 1 1/2 inch and 2 inch corporation valves tapped horizontal a minimum distance of 24 inches from pipe bell or other corporation.
- C. Construct trench and place backfill material according to [Section 3010](#).

**3.10 WATER MAIN ABANDONMENT**

Verify with the Engineer that all services are no longer using the main to be abandoned.

**A. For Each Pipe to be Abandoned by Capping:**

1. Close valves and remove valve boxes as specified in the contract documents.
2. Construct thrust blocks on each end of the active pipes according to [Figure 5010.101](#).
3. Cut pipe to be abandoned a minimum of 5 feet from the closed valve on each end of the active pipes, leaving a minimum of 12 inches of pipe exposed beyond the thrust block.
4. Remove a minimum of 3 feet of the pipe to be abandoned.
5. Install a MJ cap using a retaining gland according to [Figure 5010.101](#) on the end of each pipe to be abandoned and each active pipe.



**3.10 WATER MAIN ABANDONMENT (Continued)****B. For Each Pipe to be Abandoned by Filling:**

1. Close valves and remove valve boxes as specified in the contract documents.
2. Construct thrust blocks on each end of the active pipes according to [Figure 5010.101](#).
3. Cut pipe to be abandoned a minimum of 5 feet from the closed valve on each end of the active pipes, leaving a minimum of 12 inches of pipe exposed beyond the thrust block.
4. Remove a minimum of 3 feet of the pipe to be abandoned.
5. Install a MJ cap using a retaining gland according to [Figure 5010.101](#) on each pipe to be abandoned and each active pipe.
6. Fill the pipe to be abandoned by pumping with flowable mortar, foamed cellular concrete, or CLSM complying with [Section 3010](#).

**3.11 WATER MAIN REMOVAL**

Verify with the Engineer that all services are no longer using the main and have been disconnected from the main to be removed.

- A. Close valves as specified in the contract documents.
- B. Construct thrust block on each end of the active pipes according to [Figure 5010.101](#).
- C. Cut pipe to be removed a minimum of 5 feet from the closed valve on each end of the active pipes leaving a minimum of 12 inches of pipe exposed beyond the thrust block.
- D. Install a MJ cap using a retaining gland according to [Figure 5010.101](#) at the end of each active pipe.
- E. Remove and dispose of water main pipe. Furnish, place, and compact backfill material.

**3.12 TESTING AND DISINFECTION**

Test and disinfect according to [Section 5030](#).

END OF SECTION



*This page was intentionally left blank*

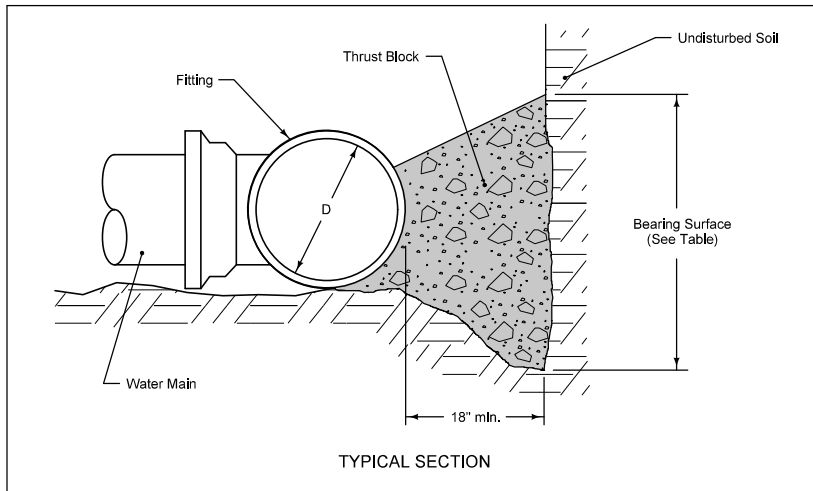

Extend thrust blocks to undisturbed soil. Excavation into trench wall may be necessary.

Form vertical surfaces of poured concrete thrust blocks except on bearing surface.

Encase all fittings in polyethylene wrap. Do not allow concrete to directly contact joints or fitting bolts.

Diameter of Pipe, D (inches)	MINIMUM BEARING SURFACE (sf)				
	Bends				Tees and Dead Ends
	11 $\frac{1}{4}$ <sup>o</sup>	22 $\frac{1}{2}$ <sup>o</sup>	45 <sup>o</sup>	90 <sup>o</sup>	
4	1	1	2	4	3
6	1	2	4	8	6
8	2	4	7	14	10
10	3	6	11	21	15
12	4	8	16	29	21
14	5	11	21	39	28
16	7	14	27	50	36
18	9	17	34	63	45
20	11	21	42	78	55
24	15	31	60	111	78
30	24	47	92	171	120
36	34	67	132	244	173

Minimum surface area based on water pressure of 150 psf and allowable soil pressure of 1,000 psf.

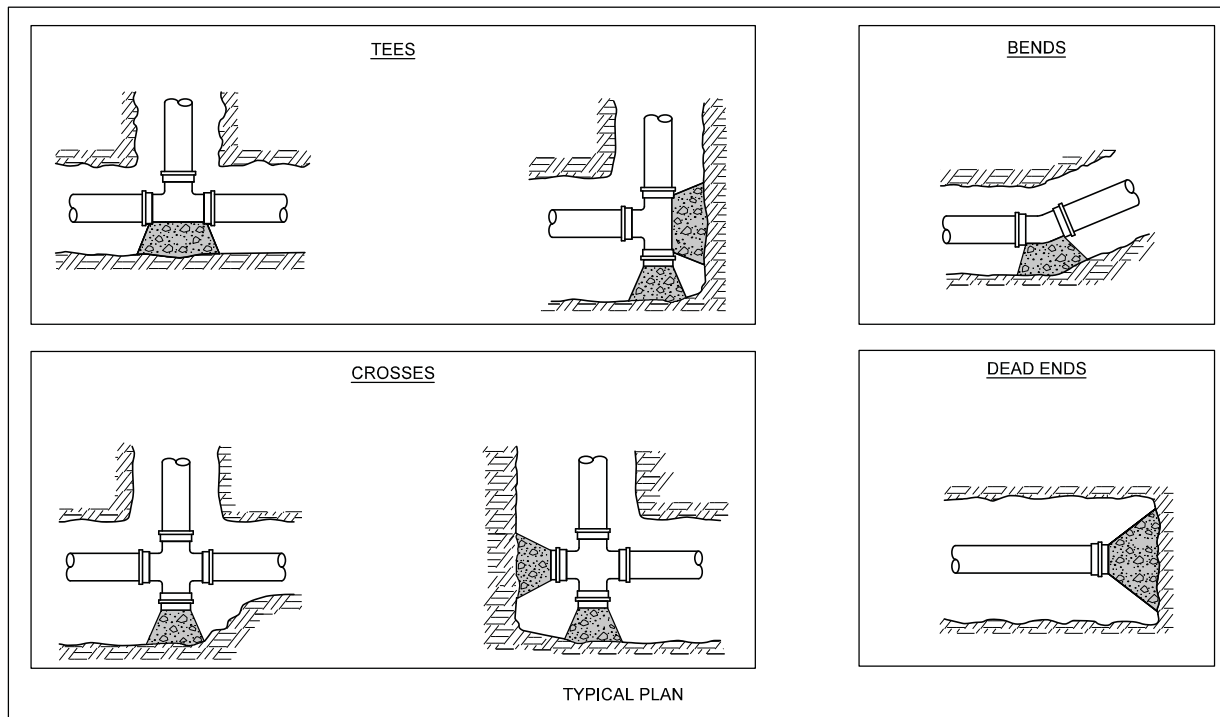
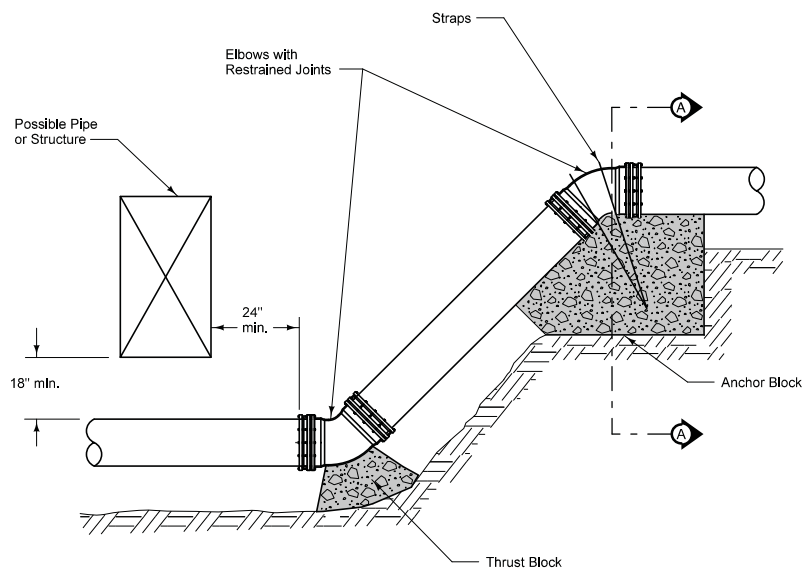

FIGURE 5010.101 SHEET 1 OF 2

SUDAS	IOWADOT	REVISION
		1   10-18-16
FIGURE 5010.101	STANDARD ROAD PLAN	<b>WM-101</b>
		SHEET 1 of 2
REVISIONS: Replaced Iowa DOT and SUDAS logos with new logos.		
Paul D. Wigand SUDAS DIRECTOR		Brian Smith DESIGN METHODS ENGINEER
<b>THRUST BLOCKS</b>		

CHANGES IN PIPE DEPTH



ELEVATION

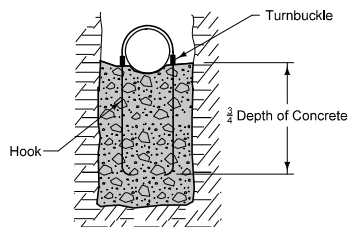

SECTION A-A

DEAD ENDS (ALTERNATE METHOD)

Use only when allowed by the Engineer, or when specified in the contract documents.

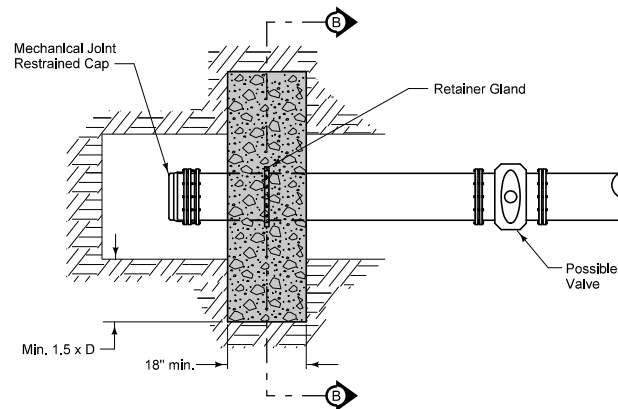

PLAN

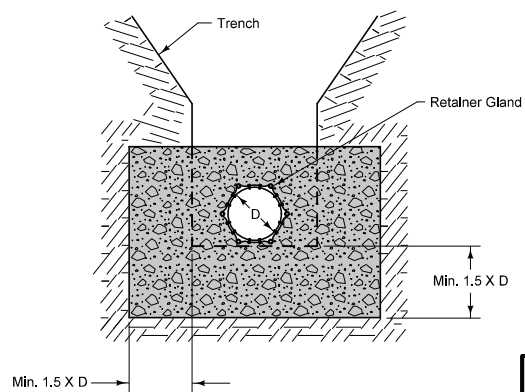

SECTION B-B

SUDAS	IOWADOT	REVISION
		1   10-18-16
FIGURE 5010.101	STANDARD ROAD PLAN	WM-101
		SHEET 2 of 2

REVISIONS: Replaced Iowa DOT and SUDAS logos with new logos.

*Paul D. Wigand* SUDAS DIRECTOR      *Brian Smith* DESIGN METHODS ENGINEER

**THRUST BLOCKS**



- ① Extend tracer wire up fire hydrant barrel to internal terminals of tracer wire station and back down. Refer to WM-201 for details of fire hydrant assembly.
- ② Clamp tracer wire to ground rod at system termination points.

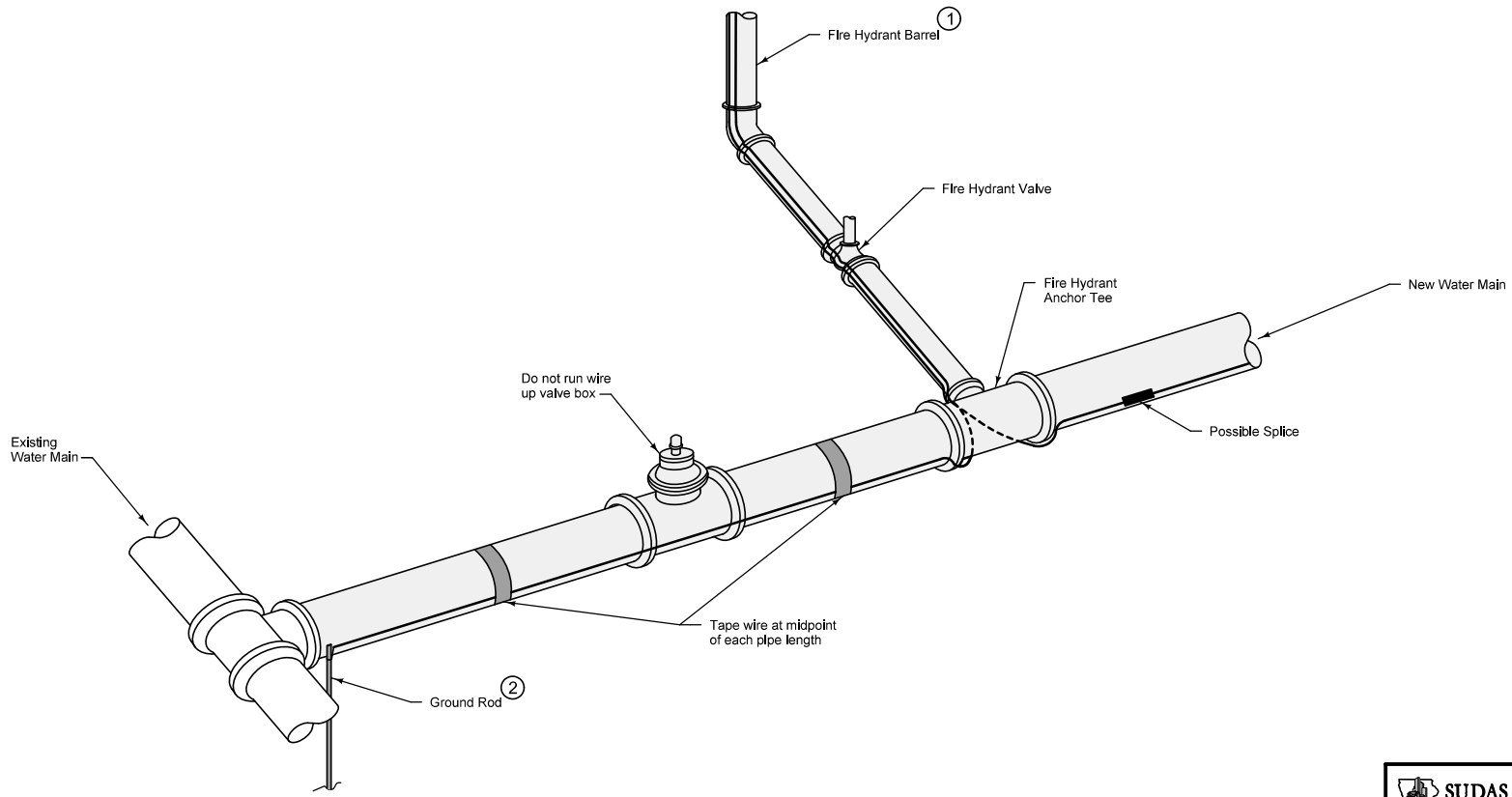

TYPICAL INSTALLATION

FIGURE 5010.102 | SHEET 1 OF 1

SUDAS	IOWADOT	REVISION	
		1	10-18-16
FIGURE 5010.102	STANDARD ROAD PLAN	<b>WM-102</b>	
		SHEET 1 of 1	
<small>REVISIONS: Replaced Iowa DOT and SUDAS logos with new logos.</small>			
Paul D. Wigand <small>SUDAS DIRECTOR</small>		Brian Smith <small>DESIGN METHODS ENGINEER</small>	
<b>TRACER SYSTEM</b>			





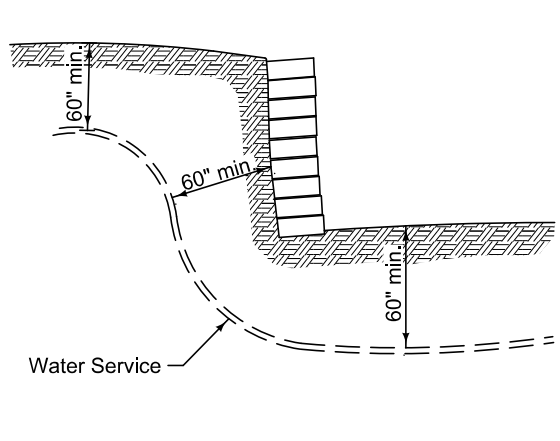

SECTION

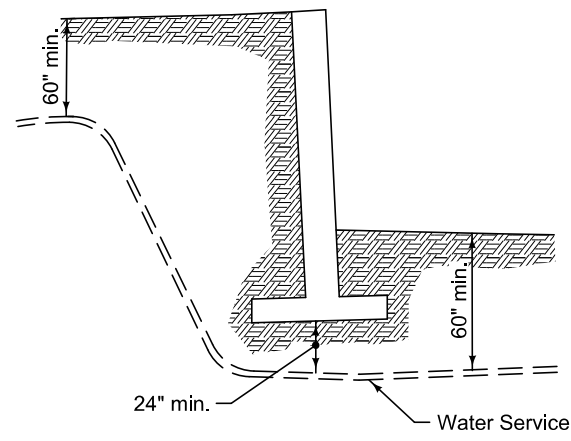

SECTION

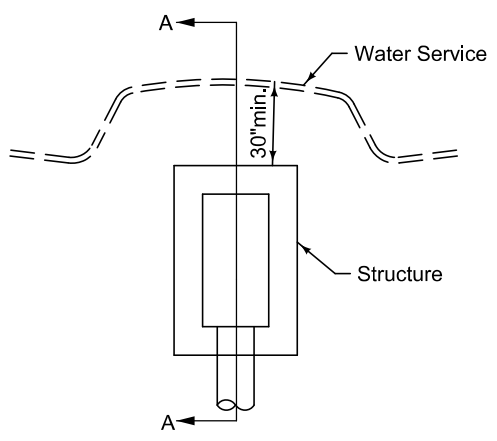

PLAN VIEW

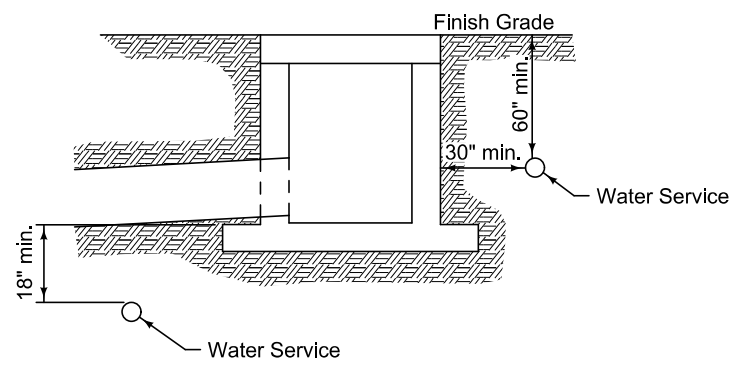

SECTION

This figure details minimum required clearances between structure and water service lines. Adjust location of water services as directed by the Engineer to maintain the clearances shown.

	REVISION 1   10-21-14
	<b>5010.901</b>
	SHEET 1 of 1
SUDAS Standard Specifications	
MINIMUM CLEARANCE BETWEEN WATER SERVICE AND STRUCTURE	



---

**FUSIBLE PVC AND HDPE PIPE****PART 1 - GENERAL****1.01 SECTION INCLUDES**

Water Main Pipe

**1.02 DESCRIPTION OF WORK**

Construct water mains.

**1.03 SUBMITTALS**

Comply with Division 1 - General Provisions and Covenants, as well as the following:

**A. Pre-Construction:**

1. Recommended Minimum Bending Radius
2. Recommended Maximum Safe Pull Force

**B. Post-Construction:**

Fusion joint report containing the following information:

1. Pipe size and thickness
2. Machine size
3. Fusion technician identification
4. Job identification
5. Fusion joint number
6. Fusion, heating, and drag pressure settings
7. Heat plate temperature
8. Time stamp
9. Heating and cool down time of fusion
10. Ambient temperature

**1.04 SUBSTITUTIONS**

Comply with Division 1 - General Provisions and Covenants.

**1.05 DELIVERY, STORAGE, AND HANDLING**

Comply with Division 1 - General Provisions and Covenants, as well as the following:

- A. Load, off-load, store, and otherwise handle pipe according to the pipe supplier's recommendations. Handle and support pipe with woven fiber pipe slings or approved equal. Do not use handling devices such as chains, wire rope, chokers, or other pipe handling implements that may scratch, nick, cut, or gouge the pipe.

**1.05 DELIVERY, STORAGE, AND HANDLING (Continued)**

- B. Exercise caution to avoid compression, damage, or deformation to the ends of the pipe during transportation to the site and while stored on site.
- C. Notify the Engineer of any damaged pipe and remove from the site; do not use in construction unless allowed by the Engineer. Pipe considered as damaged includes the following:
  - 1. Any length of pipe showing a crack.
  - 2. Any length of pipe which has received a blow that may have caused an incident fracture, even though no such fracture is visible.
  - 3. Any length of pipe with a scratch or gouge greater than 10% of the wall thickness.

**1.06 SCHEDULING AND CONFLICTS**

Comply with Division 1 - General Provisions and Covenants.

**1.07 SPECIAL REQUIREMENTS**

Perform thermal fusion of pipe by a Fusion Technician fully qualified by the pipe supplier for the type(s) and size(s) of pipe being used. Ensure qualification is current as of the date of fusion performance on the project.

**1.08 MEASUREMENT AND PAYMENT****A. Fusible Water Main:****1. Trenched:**

- a. **Measurement:** Each type and size of fusible pipe installed in an open trench will be measured in linear feet along the centerline of the pipe, including the length through the fittings.
- b. **Payment:** Payment will be made at the unit price per linear foot for each type and size of pipe.
- c. **Includes:** Unit price includes, but is not limited to, trench excavation, dewatering, furnishing bedding material, performing fusion jointing, placing bedding and backfill material, tracer system, testing, and disinfection.

**2. Trenchless:**

- a. **Measurement:** Each type and size of fusible pipe installed by trenchless methods will be measured in linear feet along the centerline of the pipe.
- b. **Payment:** Payment will be made at the unit price per linear foot for each type and size of fusible pipe.
- c. **Includes:** Unit price includes, but is not limited to, furnishing and installing pipe; performing fusion jointing, trenchless installation materials and equipment; pit excavation, dewatering, and placing backfill material; tracer system; testing; and disinfection.

---

**1.08 MEASUREMENT AND PAYMENT (Continued)****B. Water Main with Casing Pipe:****1. Trenched:**

- a. Measurement:** Each type and size of fusible pipe with a casing pipe installed in an open trench, will be measured in linear feet along the centerline of the casing pipe from end of casing to end of casing.
- b. Payment:** Payment will be made at the unit price per linear foot for each type and size of carrier pipe.
- c. Includes:** Unit price includes, but is not limited to, furnishing and installing both fusible carrier pipe and casing pipe, performing fusion jointing, trench excavation, dewatering, furnishing bedding material, placing bedding and backfill material, casing spacers, furnishing and installing annular space fill material, tracer system, testing, and disinfection.

**2. Trenchless:**

- a. Measurement:** Each type and size of fusible pipe installed by trenchless methods with a casing pipe will be measured in linear feet along the centerline of the casing pipe.
- b. Payment:** Payment will be made at the unit price per linear foot for each type and size of fusible carrier pipe.
- c. Includes:** Unit price includes, but is not limited to, furnishing and installing both fusible carrier pipe and casing pipe; performing fusion jointing, trenchless installation materials and equipment; pit excavation, dewatering, and placing backfill material; casing spacers; furnishing and installing annular space fill material; tracer system; testing; and disinfection.

---

**PART 2 - PRODUCTS****2.01 WATER MAIN**

- A. Fusible PVC Pipe:** Comply with AWWA C900 with ductile iron pipe equivalent outside diameters.
- 1. Minimum Wall Thickness:**
    - a. 4 inch through 24 inch sizes:** DR 18.
    - b. Sizes over 24 inch:** As specified in the contract documents.
  - 2. Pipe Manufacturing:**
    - a. Provide pipe extruded with plain ends square to the pipe, free of any bevel or chamfer, and without bells or gaskets of any kind.
    - b. Pipe for potable water use to be blue in color.
  - 3. Markings on Pipe:**
    - a. Name of manufacturer.
    - b. Size and class.
    - c. NSF International (NSF) seal
- B. Fusible HDPE Pipe:** Comply with AWWA C906 with ductile iron pipe equivalent outside diameters.
- 1. Material Designation Code:** PE4710.
  - 2. Minimum Wall Thickness:** DR 9.
    - a. 4 inch through 24 inch sizes: DR 9.
    - b. Sizes over 24 inch: As specified in the contract documents.
  - 3. Pipe Manufacturing:**
    - a. Provide pipe extruded with plain ends square to the pipe, free of any bevel or chamfer, and without bells or gaskets of any kind.
    - b. Pipe for potable water use to be black in color with two blue stripes.
  - 4. Markings on Pipe:**
    - a. Name of manufacturer.
    - b. Size and class.
    - c. NSF International (NSF) seal.

**PART 3 - EXECUTION**

Comply with [Section 5010, Part 3](#), as well as the following:

**3.01 ADDITIONAL REQUIREMENTS FOR FUSIBLE PIPE INSTALLATION****A. General:**

1. Thermally butt fuse pipe joints and install pipe complying with the contract documents and the pipe supplier's recommendations.
2. Assemble pipe lengths in the field with butt-fused joints. Whenever possible, fuse and stage pipe lengths in their entirety prior to installation.
3. Handle and install pipe in a manner that does not over-stress the pipe or exceed the recommended bending radius at any time.
4. Where pipe is installed by pulling in tension, do not exceed the safe pulling force at any time.
5. Once pipe installation has commenced, continue the operation without interruption until the entire length of the fused section of pipe is installed.
6. Repair sections of pipe damaged during installation by cutting out the damaged section, facing the two pipe pieces according to the tolerances set by the manufacturer, and then rejoining with standard butt-fused joints.

**B. Equipment:**

1. **Fusion Machine:** Use fusion machines in good condition, properly equipped and set up for the pipe size being fused, and approved by the pipe supplier for the fusion process. Fusion machines must incorporate the following elements:
  - a. **Heat Plate:** Free of any debris, contamination, or deep gouges or scratches; sized appropriately and capable of maintaining a uniform and consistent heat profile and temperature for the pipe being fused.
  - b. **Carriage:** Capable of smooth travel with no binding at operating loads.
  - c. **Data Logging Device:** Device compatible with the fusion machine and capable of logging a time stamp with heat plate temperature and pressure during the fusion process.
2. **Pipe Rollers:** Provide pipe rollers of sufficient quantity, spacing, and size to assure adequate support and limit excessive sagging of the pipe during handling and installation operations.
3. **Weather Canopy:** Provide a weather protection canopy which allows full motion of the fusion machine during inclement or windy weather or during extreme temperatures.
4. **Infrared (IR) Pyrometer:** For checking pipe and heat plate temperatures.
5. **Facing Blades:** Use blades specifically designed for cutting the fusible pipe being used.
6. **Pipe Pull Heads:** Where applicable, pull pipe utilizing a pull head specifically designed for use with the type of fusible pipe being used. Provide pull head that employs a positive through-bolt design assuring a smooth wall against the pipe cross-section at all times.

**3.01 ADDITIONAL REQUIREMENTS FOR FUSIBLE PIPE INSTALLATION (Continued)**

**C. Fusion Process:** Prepare and fuse pipe according to the pipe supplier's recommendations as well as the following.

1. **Joint Recording:** Record and log each fusion joint with a data logging device connected to the fusion machine. Manually log required data not logged electronically and include in the fusion joint report.
2. **Joint Finishing:** After fusing, grind the external joint bead to a maximum height of 0.1 inch. If required by the contract documents, grind the internal joint bead to a maximum height of 0.1 inch or as specified.

**D. Trenched Installation:**

1. Do not drop or roll pipe into the trench or excavation.
2. If the length of the fused pipe is longer than what the available equipment can lower into the trench or excavation at one time, stage equipment so that lowering begins at one end of the installation and proceed along the trench or excavation so that the entire fused length is installed without exceeding the minimum bend radius of the fused pipe.
3. Pipe may also be installed by pulling it into the end of the trench via a sloped section that is constructed so as not to exceed the minimum bending radius of the pipe.
4. Bed and backfill fused pipe per the contract documents and all applicable standards.

**E. Trenchless Installation:**

1. Where applicable, grade the pipe entry area as necessary to provide support for the pipe so as not to exceed the minimum bending radius of the pipe and to allow free movement into the bore hole.
2. Use a swivel attachment between the reaming head and the pipe to minimize torsion stress on the pipe assembly.

**F. Pipe Connections:**

1. Allow initial lengths of installed pipe to come to thermal equilibrium with the soil temperature at burial depth, by waiting at least 24 hours after installation prior to making connections such as service lines and laterals.
2. Tap pipe only with standard tapping saddles or sleeves designed according to AWWA C605 for PVC and AWWA M55 for HDPE. Do not direct tap fusible pipe.
3. Observe pipe supplier's guidelines for maximum tap size per pipe diameter and follow pipe supplier recommendations for tapping PVC and HDPE.
5. Use tapping bits specifically made for the pipe type being used, such as slotted shell style cutters. Do not use hole saws intended for cutting wood, steel, ductile iron, or other materials.

**3.02 TESTING AND DISINFECTION**

Test and disinfect according to [Section 5030](#).

END OF SECTION



**VALVES, FIRE HYDRANTS, AND APPURTENANCES****PART 1 - GENERAL****1.01 SECTION INCLUDES**

- A. Butterfly Valves
- B. Gate Valves
- C. Tapping Valve Assemblies
- D. Fire Hydrant Assemblies
- E. Flushing Devices (Blowoffs)
- F. Valve Boxes

**1.02 DESCRIPTION OF WORK**

Install valves, fire hydrants, and appurtenances for water mains.

**1.03 SUBMITTALS**

Comply with Division 1 - General Provisions and Covenants.

**1.04 SUBSTITUTIONS**

Comply with Division 1 - General Provisions and Covenants.

**1.05 DELIVERY, STORAGE, AND HANDLING**

Comply with Division 1 - General Provisions and Covenants, as well as the following:

Remove valves, fire hydrants, and appurtenances contaminated with mud and surface water from the site. Do not use in construction unless thoroughly cleaned, inspected, and approved by the owner.

**1.06 SCHEDULING AND CONFLICTS**

Comply with Division 1 - General Provisions and Covenants.

**1.07 SPECIAL REQUIREMENTS**

None.

**1.08 MEASUREMENT AND PAYMENT****A. Valve (Butterfly or Gate):**

1. **Measurement:** Each type and size of valve will be counted.
2. **Payment:** Payment will be at the unit price for each type and size of valve.
3. **Includes:** Unit price includes, but is not limited to, all components attached to the valve or required for its complete installation, including underground or above ground operator, square valve operating nut, valve box and cover, valve box extension, and valve stem extension.

**1.08 MEASUREMENT AND PAYMENT (Continued)****B. Tapping Valve Assembly:**

1. **Measurement:** Each size of tapping valve assembly will be counted.
2. **Payment:** Payment will be at the unit price for each tapping valve assembly.
3. **Includes:** Unit price includes, but is not limited to, tapping sleeve, tapping valve, the tap, valve box and cover, valve box extension, and valve stem extension.

**C. Fire Hydrant Assembly:**

1. **Measurement:** Each fire hydrant assembly will be counted.
2. **Payment:** Payment will be at the unit price for each fire hydrant assembly.
3. **Includes:** Unit price includes, but is not limited to, the fire hydrant, barrel extensions sufficient to achieve proper bury depth of anchoring pipe and height of fire hydrant above finished grade, and components to connect the fire hydrant to the water main, including anchoring pipe, fittings, thrust blocks, pea gravel or porous backfill material, and fire hydrant gate valve and appurtenances, except tapping valve assembly if used.

**D. Alternate Fire Hydrant Assembly:**

1. **Measurement:** Each alternate fire hydrant assembly will be counted.
2. **Payment:** Payment will be at the unit price for each alternate fire hydrant assembly.
3. **Includes:** Unit price includes, but is not limited to, the fire hydrant, barrel extensions sufficient to achieve proper bury depth of anchoring pipe and height of fire hydrant above finished grade, and components to connect the fire hydrant to the water main, including anchoring pipes, 90 degree bend; fittings, thrust blocks, pea gravel or porous backfill material, and fire hydrant gate valve and appurtenances, except tapping valve assembly if used.

**E. Flushing Device (Blowoff):**

1. **Measurement:** Each size of flushing device will be counted.
2. **Payment:** Payment will be at the unit price for each flushing device

**F. Valve Box Adjustment, Minor:** Measurement and payment for minor adjustment of an existing valve box by raising or lowering the adjustable valve box is incidental.**G. Valve Box Extension:**

1. **Measurement:** Each existing valve box adjusted to finished grade by adding a valve box extension will be counted.
2. **Payment:** Payment will be at the unit price for each valve box extension.

**1.08 MEASUREMENT AND PAYMENT (Continued)****H. Valve Box Replacement:**

1. **Measurement:** Each existing valve box replaced with a new valve box will be counted.
2. **Payment:** Payment will be at the unit price for each valve box replacement.
3. **Includes:** The unit price for each valve box replacement includes, but is not limited to, removal of existing valve box; excavation; furnishing and installing new valve box; backfill; compaction; and all other necessary appurtenances.

**I. Fire Hydrant Adjustment:**

1. **Measurement:** Each existing fire hydrant adjusted to finished grade by addition of an extension barrel section and stem will be counted.
2. **Payment:** Payment will be at the unit price for each adjustment of an existing fire hydrant.
3. **Includes:** The unit price for each adjustment of an existing fire hydrant includes, but is not limited to, removal and reinstallation of the existing fire hydrant; furnishing and installing the extension barrel section and stem; and all other necessary appurtenances.

**J. Fire Hydrant Assembly Removal:**

1. **Measurement:** Each fire hydrant assembly removed will be counted.
2. **Payment:** Payment will be made at the unit price for each fire hydrant assembly removed.
3. **Includes:** The unit price includes, but is not limited to, excavation, removal of the fire hydrant, hydrant valve, thrust block, delivery of the fire hydrant assembly to the Contracting Authority (if specified), capping of the pipe, backfill, compaction, and surface restoration to match the surrounding area.

**K. Valve Removal:**

1. **Measurement:** Each size of valve removed will be counted
2. **Payment:** Payment will be made at the unit price for each size of valve removed.
3. **Includes:** The unit price includes, but is not limited to, excavation, removal of each valve, replacing the removed valve with pipe and connections if required or capping the former valve connection, delivery of the valve to the Contracting Authority (if specified), backfill, compaction, and surface restoration to match the surrounding area.

**L. Valve Box Removal:**

1. **Measurement:** Each valve box removed will be counted
2. **Payment:** Payment will be made at the unit price for valve box removed.
3. **Includes:** The unit price includes, but is not limited to, excavation, removal of each valve box, delivery of the valve box to the Contracting Authority (if specified), backfill, compaction, and surface restoration to match the surrounding area.

**PART 2 - PRODUCTS****2.01 VALVES****A. General:**

1. **Valve Body:** Manufacturer's name and pressure rating cast on valve body.
2. **Direction of Opening:** The opening direction is counterclockwise as viewed from the top, unless otherwise specified in the contract documents or as directed by the Jurisdiction.
3. **Joints:**
  - a. For buried installations, use mechanical joints per AWWA C111. Comply with [Section 5010](#) for joint nuts and bolts.
  - b. For installation within structures, flanged with dimensions and drillings according to AWWA C110 or ANSI B16.1 class 125.

**B. Gate Valves:**

1. **Standards:** Comply with AWWA C509 (gray iron or ductile iron) or AWWA C515 (ductile iron) and NSF 61.
2. **Stem Seals:** Double O-rings permanently lubricated between seals. Lubricant certified for use in potable water.
3. **External Bolts and Hex Nuts:** Stainless steel according to ASTM A 240, Type 304.

**C. Butterfly Valves:**

1. **Standards:** Comply with AWWA C504 class 150B (gray iron or ductile iron) and NSF 61.
2. **Stem:** Stainless steel according to ASTM A 240, Type 304, turned, ground, and polished.
3. **For Seat on Body Valves:**
  - a. **Disc:** Ductile iron or gray iron with plasma applied nickel-chromium edge or stainless steel edge according to ASTM A 240, Type 316, and mechanically fixed stainless steel pins.
  - b. **Seat:** Synthetic rubber compound mechanically retained to the body.
4. **For Seat on Disc Valves:**
  - a. **Disc:** Ductile iron according to ASTM A 536 with synthetic rubber compound seat mechanically retained to the disc.
  - b. **Seat:** Continuous Type 316 stainless steel seat.
5. **External Bolts and Hex Nuts:** Stainless steel according to ASTM A 240, Type 304.

**D. Tapping Valve Assemblies:**

1. **Tapping Valve:** Gate valve complying with AWWA C509 or AWWA C515.
2. **Sleeve:**
  - a. Minimum 14 gauge.
  - b. Stainless steel according to ASTM A 240, Type 304.
  - c. Working pressure 150 psi.
  - d. Must fully surround pipe.
  - e. Flanged with dimensions and drillings according to AWWA C110 or ANSI B16.1 class 125.

**2.01 VALVES (Continued)**

3. **Minimum Sleeve Length:** Comply with the following table.

**Table 5020.01: Minimum Sleeve Length**

<b>Outlet Flange Size</b>	<b>Minimum Sleeve Length</b>
4"	15"
6"	15"
8"	20"
10"	25"
12"	25"
Over 12"	As approved by the Engineer

4. **Gasket:**
- To completely surround pipe.
  - Minimum thickness 0.125 inch.
  - Use nitrile rubber.
5. **Outlet Flange:**
- Stainless steel complying with ASTM A 240, Type 304.
  - ANSI B16.1, 125 pound pattern.
6. **Hex Nuts and Bolts:** Stainless steel complying with ASTM A 240, Type 304.
7. **Tapping Valve Assemblies:** Use only where specified in the contract documents.

**2.02 FIRE HYDRANT ASSEMBLY**

- A. **Material:** Comply with AWWA C502.
- B. **Manufacturers:** As allowed by the Jurisdiction or as specified in the contract documents.
- C. **Features:**
- Breakaway Items:** Stem coupling and flange.
  - Inlet Nominal Size:** 6 inch diameter.
  - Inlet Connection Type:** Mechanical joint.
  - Hose Nozzles:** Two, each 2 1/2 inches in diameter.
  - Direction of Opening:** Counterclockwise, unless otherwise specified.
  - Items to be Specified:** The following items will be specified by the Jurisdiction or in the contract documents.
    - Operating nut.
    - Pumper nozzle.
    - Nozzle threads.
    - Main valve nominal opening size.
- D. **Painting:**
- Shop coating according to AWWA C502.
  - Above grade exterior coating type and color will be selected by the Engineer.
- E. **External Bolts and Hex Nuts:** Stainless steel according to ASTM A 193, Grade B 8.
- F. **Gate Valve:** Comply with Section 5020, 2.01.
- G. **Pipe and Fittings:** Comply with [Section 5010](#).

**2.03 APPURTENANCES**

- A. Flushing Device (Blowoff):** As specified in the contract documents.
- B. Valve Box:**
1. **Applicability:** For all buried valves.
  2. **Manufacturer:** As allowed by the Jurisdiction or specified in the contract documents.
  3. **Type:**
    - a. In paved areas, use a slide type.
    - b. In all other areas, use a screw extension type.
  4. **Material:** Gray iron.
  5. **Cover:** Gray iron, labeled "WATER"
  6. **Wall Thickness:** 3/16 inch, minimum.
  7. **Inside Diameter:** 5 inches, minimum.
  8. **Length:** Adequate to bring top to finished grade, including valve box extensions, if necessary.
  9. **Factory Finish:** Asphalt coating.
  10. **Valve Box Centering Ring:** Include in installation.
- C. Valve Stem Extension:** For all buried valves, provide as necessary to raise 2 inch operating nut to within 3 feet of the finished grade. Stem diameter according to valve manufacturer's recommendations, but not less than 1 inch.

**PART 3 - EXECUTION****3.01 GENERAL**

- A. Install according to the contract documents.
- B. Apply polyethylene wrap to all iron pipe, valves, fire hydrants, and fittings.
- C. Set tops of valve boxes to finished grade, unless otherwise directed by the Engineer.
- D. Check the working order of all valves by opening and closing through entire range. Before opening the valves, check with the Jurisdiction on operating requirements.
- E. Test and disinfect all valves, fire hydrants, and appurtenances as components of the completed water main according to [Section 5030](#).

**3.02 FLUSHING DEVICE (BLOWOFF)**

Install and construct as specified in the contract documents.

**3.03 FIRE HYDRANT**

- A. Install according to [Figure 5020.201](#). Ensure a 3 foot clear space around the circumference of the fire hydrant. Place anchor tee and hydrant in the locations specified in the contract documents.
- B. If the fire hydrant valve is positioned adjacent to the water main, attach it to an anchor tee.
- C. If the fire hydrant valve is positioned away from the water main, restrain all joints between the valve and water main.
- D. Fire Hydrant Depth Setting:
  - 1. Use adjacent finished grade to determine setting depth.
  - 2. Set bottom of breakaway flange between 2 and 5 inches above finished grade.
  - 3. If finished grade is not to be completed during the current project, consult with the Engineer for proper setting depth.
- E. Coordinate installation with tracer wire installation.
- F. Orient fire hydrant nozzles parallel with or at right angles to the curb, with the pumper nozzle facing the curb. Set hydrants having two hose nozzles 90 degrees apart with each nozzle facing the curb at an angle of 45 degrees or as directed by the Engineer.

**3.04 ADJUSTMENT OF EXISTING VALVE BOX OR FIRE HYDRANT**

- A. Minor Valve Box Adjustment:** For existing adjustable boxes that have sufficient adjustment range to bring to finished grade, raise or lower valve box to finished grade.
- B. Valve Box Extension:** For existing valve boxes that cannot be adjusted to finished grade, install valve box extensions as required.
- C. Valve Box Replacement:** For existing valve boxes that cannot be adjusted to finished grade, remove and replace the valve box.

**3.04 ADJUSTMENT OF EXISTING VALVE BOX OR FIRE HYDRANT (Continued)**

**D. Fire Hydrant Adjustment:**

1. Add extension barrel sections and stems as necessary to set existing fire hydrant at finished grade.
2. Paint exterior of new barrel section to match existing fire hydrant unless otherwise specified.

END OF SECTION



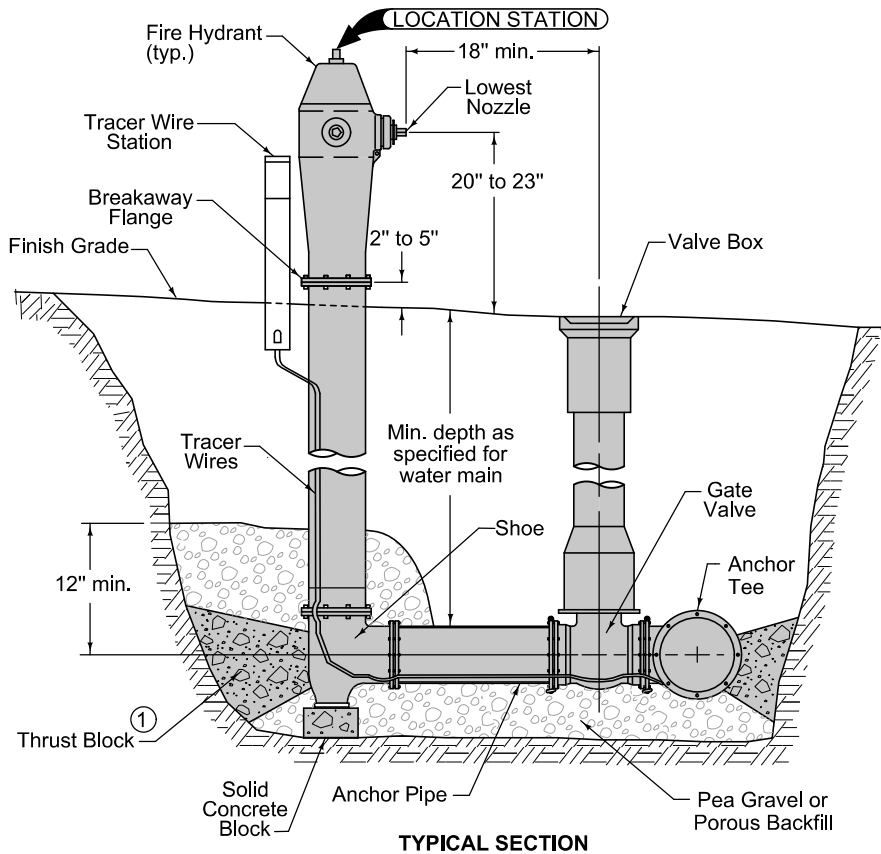

TYPICAL SECTION

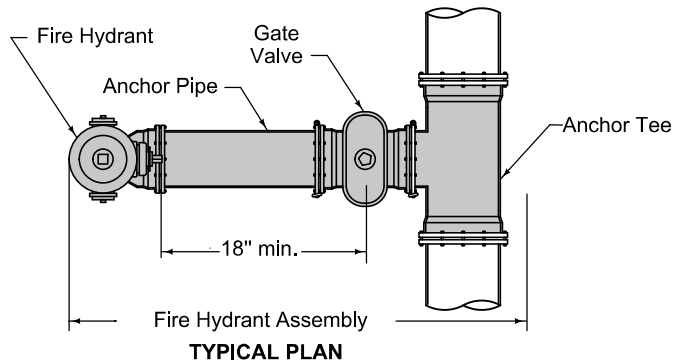

TYPICAL PLAN

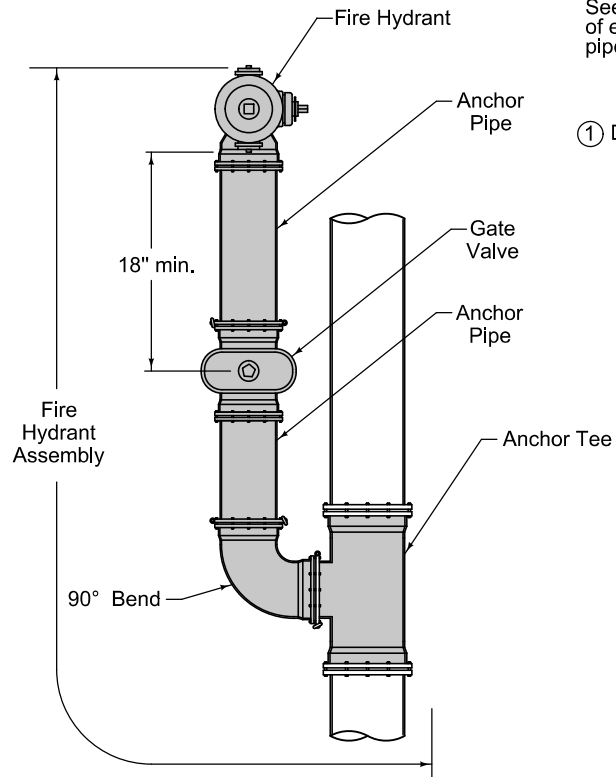

ALTERNATE PLAN

Use ductile iron pipe with restrained mechanical joints for fire hydrant assembly and anchor tee.

All shaded items are included in the Fire Hydrant Assembly bid item.

See the contract documents for the location of each hydrant and the length of anchoring pipe.

① Do not cover drain holes or tracer wire.

FIGURE 5020.201 SHEET 1 OF 1

SUDAS IOWADOT	REVISION 4 04-19-22
	<b>WM-201</b> SHEET 1 of 1
REVISIONS: Added general note for location and length.	
<i>Paul D. Wigand</i> SUDAS DIRECTOR	<i>Stuart Miller</i> DESIGN METHODS ENGINEER
<b>FIRE HYDRANT ASSEMBLY</b>	



**TESTING AND DISINFECTION****PART 1 - GENERAL****1.01 SECTION INCLUDES**

- A. Pressure and Leak Testing of Water System
- B. Disinfection of Potable Water Systems

**1.02 DESCRIPTION OF WORK**

Test and disinfect water mains, valves, fire hydrants, and appurtenances.

**1.03 SUBMITTALS**

Comply with Division 1 - General Provisions and Covenants.

**1.04 SUBSTITUTIONS**

Comply with Division 1 - General Provisions and Covenants.

**1.05 DELIVERY, STORAGE, AND HANDLING**

Comply with Division 1 - General Provisions and Covenants.

**1.06 SCHEDULING AND CONFLICTS**

Comply with Division 1 - General Provisions and Covenants, as well as the following:

- A. Notify the Engineer two working days in advance of testing or disinfection operations to coordinate the operations.
- B. The Engineer or his/her representative is required to be in attendance during testing or disinfection.

**1.07 SPECIAL REQUIREMENTS**

None.

**1.08 MEASUREMENT AND PAYMENT**

Testing and disinfection of water systems is incidental to the construction of pipe and fittings.

**PART 2 - PRODUCTS**

**2.01 DISINFECTION AGENT - CHLORINE**

- A. Liquid Chlorine complying with AWWA B300 and AWWA B301.
- B. Sodium Hypochlorite complying with AWWA B300.
- C. Calcium Hypochlorite complying with AWWA B300.
- D. All disinfecting agents to be NSF 60 certified. Supply and store in the original container.

**PART 3 - EXECUTION****3.01 GENERAL**

Perform operations according to AWWA C651 in the sequence below. Successfully complete each operation specified in subsections 3.02 through 3.08 below before continuing to the next operation. The Jurisdiction will provide reasonable quantities of water for flushing and testing.

**3.02 SEQUENCE OF TESTING AND DISINFECTION**

**A. Continuous-Feed or Slug Method (After Water Main Installation):** The sequence of testing and disinfection may be modified with approval of the Engineer.

1. Perform initial flush.
2. Perform disinfection.
3. Flush after disinfection.
4. Perform pressure and leak testing.

**B. Tablet Method (Concurrent with Water Main Installation):** Use this method only if approved by the Engineer. Modify the procedure for flushing, disinfection, and pressure and leak testing as needed if tablet method is used.

1. Perform disinfection.
2. Flush after disinfection.
3. Perform pressure and leak testing.

**3.03 INITIAL FLUSHING****A. Flushing:**

1. Coordinate flushing with the Jurisdiction.
2. Flush pipe prior to disinfection using potable water.
3. Measure flushing velocity.
4. Obtain a minimum flushing velocity of 3 feet per second in the pipe to be disinfected.

**B. Minimum Flushing Rate:** According to AWWA C651, Table 3, based on 40 psi residual pressure (see table below).

**Table 5030.01: Minimum Flushing Rate**

Pipe Diameter (inches)	Flow Rate for Flushing (gpm)	Number of Taps <sup>2</sup>			Number of 2 1/2" Fire Hydrant Outlets <sup>1</sup>
		1"	1 1/2"	2"	
4	120	1	-	-	1
6	260	-	1	-	1
8	470	-	2	-	1
10	730	-	3	2	1
12	1,060	-	-	3	2
16	1,880	-	-	5	2

<sup>1</sup>With a 40 psi pressure in the main with the fire hydrant flowing to atmosphere, a 2 1/2 inch fire hydrant outlet will discharge approximately 1,000 gpm; and a 4 1/2 inch fire hydrant outlet will discharge approximately 2,500 gpm.

<sup>2</sup>Number of taps on pipe based on discharge through 5 feet of galvanized iron pipe with one 90° elbow.

**3.03 INITIAL FLUSHING (Continued)**

- C. Property Protection:** Protect public and private property from damage during flushing operations.

**3.04 PRESSURE AND LEAK TESTING**

- A. Remove debris from within the pipe. Clean and swab out pipe, if required.
- B. Secure unrestrained pipe ends against uncontrolled movement.
- C. Isolate new piping from the existing water system.
- D. Fill and flush all new piping with potable water. Ensure all trapped air is removed.
- E. Pressurize the new pipe to the test pressure at the highest point in the isolated system. Do not pressurize to more than 5 psi over the test pressure at the highest point in the isolated system.
- F. Test and monitor the completed piping system at 1.5 times the system working pressure or 150 psi, whichever is greater, for 2 continuous hours.
- G. If at any time during the test the pressure drops to 5 psi below the test pressure, repressurize the pipe by pumping in potable water in sufficient quantity to bring the pressure back to the original test pressure.
- H. Accurately measure the amount of water required to repressurize the system to the test pressure.
- I. Maximum allowable leakage rate:

$$L = \frac{(S)(D)(P)^{0.5}}{148,000}$$

Where:

L = allowable leakage, in gallons per hour

S = length of pipe tested, in feet

D = nominal pipe diameter, in inches

P = average test pressure, in pounds per square inch

The following table assumes an average test pressure (P) of 150 psi and 1,000 feet of test section.

**Table 5030.03: Maximum Allowable Leakage Rate**

<b>Pipe Diameter (inches)</b>	<b>Allowable Leakage Rate (gallons/hour/1,000 feet of pipe)</b>
4	0.33
6	0.50
8	0.66
10	0.83
12	0.99
14	1.16
16	1.32
18	1.49
20	1.66
24	1.99
30	2.48
36	2.98

**3.04 PRESSURE AND LEAK TESTING (Continued)**

- J. If the average measured leakage per hour exceeds the maximum allowable leakage rate, repair and retest the water main.
- K. If the measured pressure loss does not exceed 5 psi, the test will be considered acceptable.
- L. Repair all visible leaks regardless of the amount of leakage.

**3.05 DISINFECTION****A. General:**

1. Disinfect according to AWWA C651. The tablet method contained in AWWA C651 is not to be used unless approved by the Engineer.
2. Keep piping to be chlorinated isolated from lines in service and from points of use.
3. Coordinate disinfection and testing with the Engineer.

**B. Procedure:**

1. Induce a flow of potable water through the pipe.
2. Introduce highly chlorinated water to the pipe at a point within 5 pipe diameters of the pipe's connection to an existing potable system, or within 5 pipe diameters of a closed end, if there is no connection to an existing system.
3. Introduce water containing a minimum of 25 mg/L free chlorine until the entire new pipe contains a minimum of 25 mg/L free chlorine.
4. Retain chlorinated water in the pipe for at least 24 hours and no more than 48 hours.

**3.06 FINAL FLUSHING**

- A. Flush pipe using potable water until chlorine residual equals that of the existing potable water system.
- B. Dispose of chlorinated water to prevent damage to the environment. Dechlorinate highly chlorinated water from testing before releasing into the ground or sewers. Obtain Jurisdiction approval prior to flushing activities.
  1. Check with the local sewer department for the conditions of disposal to the sanitary sewer.
  2. Chlorine residual of water being disposed will be neutralized by treating with one of the chemicals listed in the following table.

**3.06 FINAL FLUSHING (Continued)****Table 5030.02: Amounts of Chemicals Required to Neutralize Various Residual Chlorine Concentrations in 100,000 Gallons of Water**

Residual Chlorine Concentration mg/L	Sulfur Dioxide (SO <sub>2</sub> ) lb	Sodium Bisulfite (NaHSO <sub>3</sub> ) lb	Sodium Sulfite (Na <sub>2</sub> SO <sub>3</sub> ) lb	Sodium Thiosulfate (Na <sub>2</sub> S <sub>2</sub> O <sub>3</sub> + 5H <sub>2</sub> O) lb	Ascorbic Acid (C <sub>6</sub> O <sub>8</sub> H <sub>6</sub> ) lb
1	0.8	1.2	1.4	1.2	2.1
2	1.7	2.5	2.9	2.4	4.2
10	8.3	12.5	14.6	12.0	20.9
50	41.7	62.6	73.0	60.0	104

**3.07 BACTERIA SAMPLING**

Test water mains according to AWWA C651, except as modified below:

- A. Collect samples every 1,200 feet of new water main plus one set from the end of the line and at least one from each branch greater than one pipe length. If trench water entered the new main during construction, or if excessive quantities of dirt and debris entered the main, reduce the sampling interval to every 200 feet of new main.
- B. Collect samples according to one of the following methods as directed by the Engineer:
  1. Collect an initial set of samples after flushing and then an additional set after a minimum of 24 hours without any water use. The engineer may reduce the sampling interval to 16 hours.
  2. Allow water to sit in the new main for a minimum of 16 hours after flushing without any water use. Collect an initial set of samples and allow the sampling ports to run for a minimum of 15 minutes. Collect a second set of samples from the sampling ports.

**3.08 RE-DISINFECTION**

If the initial disinfection fails to produce satisfactory bacteriological samples, flush the main again and reinitiate the sampling process. If check samples show the presence of coliform organisms, re-chlorinate the main prior to flushing and sampling until satisfactory results are obtained.

**3.09 PUTTING WATER MAIN IN SERVICE**

Put the completed water system in service only after both sets of bacterial samples have passed and obtaining permission from the Jurisdiction.

END OF SECTION